



3170 Wasson Road • Cincinnati, OH 45209 USA
Phone 513-533-5600 • Fax 513-871-0105
E-Mail: info@richardsind.com • www.jordanvalve.com

I & M 501/502

*Installation & Maintenance Instructions for
Mark 501/502 High Flow Back Pressure Regulators*

Warning: Jordan Valve Back Pressure Regulators must only be used, installed, and repaired in accordance with these Installation & Maintenance Instructions. Observe all applicable public and company codes and regulations. In the event of leakage or other malfunction, call a qualified service person; continued operation may cause system failure or a general hazard. Before servicing any valve, disconnect, shut off, or bypass all pressurized fluid. Before disassembling a valve, be sure to release all spring tension.

Ideal Installation Schematic

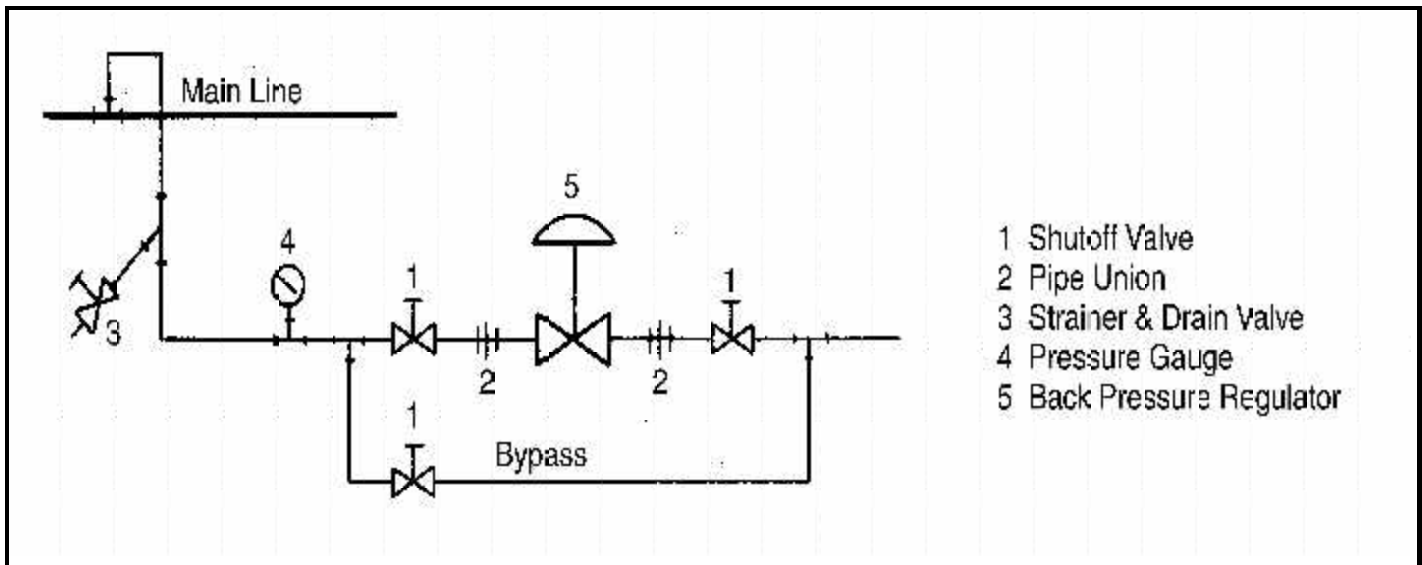

- 1 Shutoff Valve
- 2 Pipe Union
- 3 Strainer & Drain Valve
- 4 Pressure Gauge
- 5 Back Pressure Regulator

Please read these instructions carefully!

Your Jordan Valve product will provide you with long, trouble-free service if it is correctly installed and maintained. Spending a few minutes now reading these instructions can save hours of trouble and downtime later. When making repairs, use only genuine Jordan Valve parts, available for immediate shipment from the factory.

Valve Installation

1. To protect the regulator from grit, scale, thread chips, and other foreign matter, all pipe lines and piping components should be blown out and thoroughly cleaned before the regulator is installed.
2. Shutoff valves, pressure gauges, and bypass piping should be installed as indicated in the diagram to provide easier adjustment, operation, and testing.
3. In preparing threaded pipe connections, care should be exercised to prevent pipe sealing compound from getting into the pipe lines. Pipe sealing compound should be used sparingly, leaving the two end threads clean. Jordan uses, and recommends, thread sealer Teflon ribbon.
4. **A LINE STRAINER SHOULD BE INSTALLED ON THE INLET SIDE OF THE REGULATOR TO PROTECT IT FROM GRIT, SCALE AND OTHER FOREIGN MATTER.**

6. Body & end cap should be retightened per torque procedures after valve reaches operating temp.

A .033 PERFORATED SCREEN IS USUALLY SUITABLE. LINE STRAINERS ARE AVAILABLE FROM JORDAN VALVE.

5. Install the regulator in the highest horizontal line of piping to provide drainage for inlet and outlet piping, to prevent water hammer, and to obtain faster regulation.
6. The flow arrow on the regulator body must be pointed in the direction of flow. The regulator may be installed vertically or horizontally without affecting its operation.
7. For best control, 3' - 0" straight sections of pipe should be installed on either side of the regulator.
8. In hot vapor lines, upstream piping near the regulator should be insulated to minimize condensation.

Start-Up Procedure

With the inlet and outlet shutoff valves closed:

1. Throttle the bypass valve so that the pressure to be controlled is maintained near the set point.
2. Slowly open the inlet shutoff valve.
3. Open the outlet shutoff valve.
4. Slowly close the bypass valve, but do not close it fully until you are certain that the regulator has control of the system.
5. To change the controlled pressure, turn the adjusting screw clockwise to increase pressure, counterclockwise to decrease pressure.

Maintenance

Caution: Make certain that there is no pressure in the valve before loosening any fittings or joints. The following steps are recommended:

1. Close inlet shutoff valve.
2. Allow pressure to bleed off through downstream piping. Do not cause a reverse flow through valve by bleeding pressure from upstream side of valve.
3. When downstream pressure gauge indicates no pressure in the line, close the outlet shutoff valve.

Valve Seats

A. DISASSEMBLY

The seats of Jordan regulators are precision-lapped. Maintaining such tolerances is of paramount importance for your assurance of excellent control and tight shutoff. Do not use metallic objects in removing the seats. Care in handling is imperative.

1. Close shutoff valve on each side of the regulator.
2. Remove the regulator from line.
3. Secure the inlet *body* hex in the vise. Remove the *cap bolts* and lift *cap* straight up.
4. Remove the *disc* and *plate* assembly by lifting the assembly straight up from the valve *body*. Place the assembly on the bench with the *disc* up. Remove the *pressure ring*.

SPECIAL NOTE: It is imperative that the *disc pin* is not rotated in disassembly, cleaning, or reassembly, since this affects the stroke adjustment of the valve.

5. Clean the *plate* seat with fine emery cloth. Clean the *body* and *cap* cores with good quality solvent.
6. To clean the *disc* and *plate*, remove the *guide screws*. Place 4/0 polishing cloth or jeweler's cloth on a smooth, flat surface, and polish the lapped surfaces of the *disc* and *plate*. If these parts are scarred, do not attempt to relap them, but return them to the factory for repair or replacement. The *pressure ring* may be polished in the same manner.

B. REASSEMBLY

1. Place *disc* on the *plate* and replace the *guide screws*. Tighten the *guide screws* but do not allow the screws to bind the *disc* against the *plate*.
2. Replace the *pressure ring* and the *disc/plate* assembly. Make sure that the *disc pin* engages the *disc* and that the *plate* seats solidly against the plate seat in the body.

3. Check the orifice alignment of the *disc* and *plate* by releasing the compression of the *range spring* and then stroking the valve fully upwards. (*To stroke valve upwards, pry the disc pin upwards with a screwdriver through the inlet of the valve -- see figure on next page.*) In this position, the orifices of the *disc* and *plate* must be fully open and in perfect alignment. If the orifices are not aligned, the *disc pin* has probably been rotated. Remove the *disc* and *plate* assembly and rotate the *disc pin* to raise it or lower it for proper alignment.
4. If further adjustment of the *disc pin* does not provide perfect alignment, proceed to **VALVE STROKE ADJUSTMENT**.
5. Once the orifices in the *plate* and *disc* are properly aligned, place a straight edge across the body bolt holes on the horizontal center line of the valve (perpendicular to the valve movement.) Gently rotate the *disc* and *plate* assembly until the edges of the orifice slots are parallel to the straight edge and replace the *cap*, being careful not to rotate the *disc* and *plate* assembly.
6. Replace the *cap* and *cap bolts*, and tighten uniformly, being careful not to torque excessively. See back page for recommended torque values.

Diaphragm Replacement

A. DISASSEMBLY

1. In removing the *diaphragm*, you must first remove the valve *disc* and valve *plate*. This is outlined under **VALVE SEATS**.
2. Remove the compression of the *adjusting spring* by rotating the *adjusting screw* counterclockwise.
3. Remove the *spring housing bolts* and *spring housing*. Remove *adjusting spring* and *spring seat*.
4. Hold the *disc pin* with an open end wrench and remove the *diaphragm assembly* by rotating counterclockwise. The *diaphragm assembly* consists of the *upper diaphragm plate*, *diaphragm*, and *lower diaphragm plate*.
5. If the *diaphragm* must be replaced, secure the *upper diaphragm plate* in the vise. A face spanner wrench should be used to remove the *lower diaphragm plate* from the assembly. If a face spanner wrench is not available, use a punch and hammer, but make certain to remove all burrs prior to reassembling.

B. ASSEMBLY AND STROKE ADJUSTMENT

1. The valve stroke adjustment is determined by how far the diaphragm assembly is screwed onto the stem. Hold the *disc pin* with an open end wrench and screw the *diaphragm assembly* onto the valve *stem* all the way, and back off two turns initially.

2. To check the stroke adjustment, put the *pressure ring*, valve *disc*, and valve *plate* in position in the valve *body*, using the same precautions outlined under **VALVE SEATS**.
3. Secure the *spring housing* to the valve *body* with two *spring housing bolts* and tighten.
4. Using a small screwdriver through the upstream opening of the valve *body*, stroke the valve against the upper travel stop of the *spring housing*. The orifices should be aligned in the full open position.

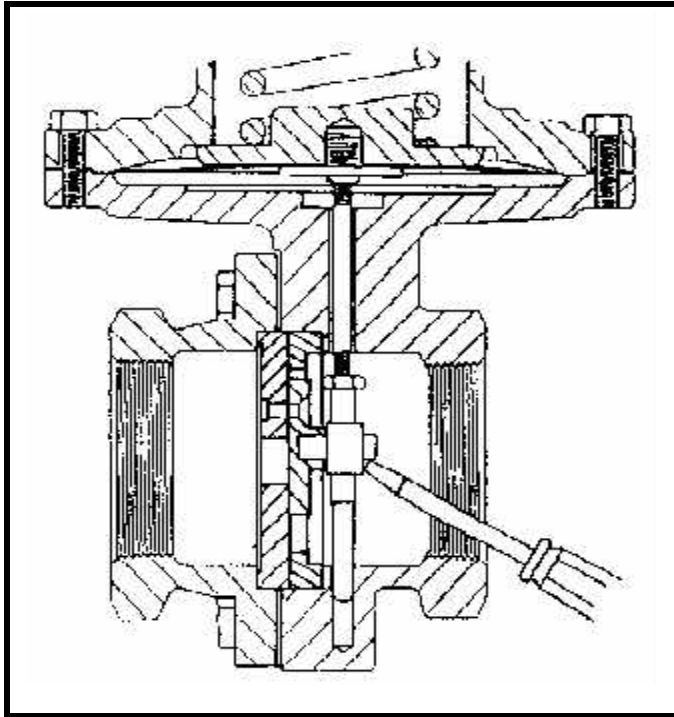

5. If the orifices are not aligned in the open position, remove the *spring housing* and rotate the *diaphragm assembly* counterclockwise to lower the *disc*, and clockwise to raise the *disc*.
6. A further check on the stroke adjustment can be made by checking the orifices in the closed position. This is a "normally closed" valve, and there should be a 1/32" overlap when the *diaphragm assembly* is down against the valve body.
7. Remove the valve *plate* and the valve *disc* to eliminate the possibility of damage during the topworks reassembly.
8. Reassemble the *adjusting spring* and *spring seat*.
9. Before replacing the *spring housing*, make certain that the *diaphragm* is centered in the body recess. This recess aligns the *spring housing* and *diaphragm*.
10. In replacing the *spring housing*, make certain that it seats properly in the valve body recess.
11. Replace the *spring housing bolts* and tighten only finger tight. Thread the *adjusting screw* into the *spring housing* until the seats are in their fully closed position. Tighten the *spring housing bolts* to the torque values shown on the

last page of this document.

12. Replace the *pressure ring*, *disc*, *plate*, and *cap*. See last page of this document for recommended torque.

Disc Pin and Stem

1. Remove the valve *disc* and valve *plate* as explained under **VALVE SEATS**.
2. Remove the *diaphragm* and topworks as described under **DIAPHRAGM REPLACEMENT**.
3. Hold the *disc pin* with an open end wrench and loosen the *locknut*. Now the *stem* may be unscrewed from the *disc pin* and removed.
4. To reassemble, first insert the *disc pin* into the valve *body*; followed by the *stem* and *locknut*. Screw the *stem* into the *disc pin* about 1/4" or midway on the stem threads and lock the *locknut* against the *disc pin*.
5. To reassemble the *diaphragm* and topworks and valve seats, refer to the reassembly instructions under **VALVE SEATS** and **DIAPHRAGM REPLACEMENT**.

Troubleshooting

If You Experience Erratic Control:

Oversizing causes cycling and hunting, and reduces the rangeability of the valve. Make certain that your sizing is correct.

Excessive foreign matter may be on seats; clean seats.

Valve stroke may be out of adjustment.; readjust and tighten locknuts securely.

Valve disc may not be moving freely; inspect and clean.

Moving parts may be binding; inspect and realign or replace if necessary.

If Valve Will Not Operate:

Diaphragm may be ruptured and require replacement.

Adjusting spring may be broken and require replacement.

Spring may be set improperly and require resetting.

Ordering Spare Parts

Jordan Valves are ruggedly built, carefully assembled to accurate dimensions, and individually tested for performance. A complete stock of finished parts is maintained for immediate delivery. In order to supply you with the precise parts designed for your specific valve, please supply the following:

- Valve serial number (found on nameplate)
- Valve model number
- Body size
- Body material
- End connections (if flanged, supply flange rating)
- Spring range or set point

Illustration & Parts List

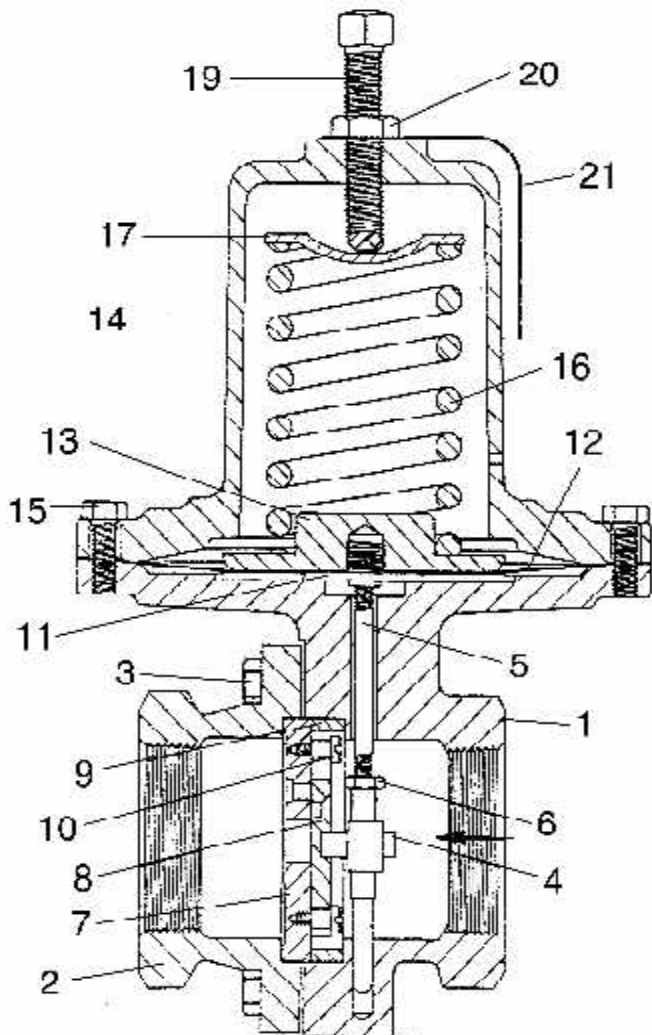

DESIGNATOR	DESCRIPTION	QTY
1	BODY	1
2	CAP	1
3	CAP BOLT	8
*4	DISC PIN	1
*5	STEM	1
*6	LOCKNUT	1
*7	PLATE	1
*8	DISC	1
*9	PRESSURE RING	1
*10	GUIDE SCREWS	2
11	LOWER DIAPHRAGM PLATE	1
*12	DIAPHRAGM	1
13	UPPER DIAPHRAGM PLATE	1
14	SPRING HOUSING	1
15	SPRING HOUSING BOLT	12
16	RANGE SPRING	A.R.
17	SPRING SEAT	1
19	ADJUSTING SCREW	1
20	JAM NUT	1
21	NAMEPLATE	1
*	RECOMMENDED SPARE PARTS	

Torque Values

Bolt Pattern/Torque Sequence

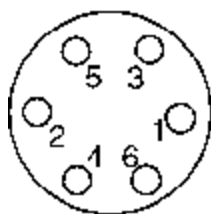

6 Bolts
(or multiples)

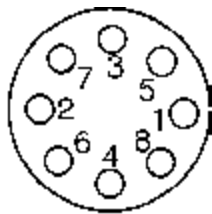

8 Bolts
(or multiples)

Torque for bolts connecting valve cap to valve body (in/lbs)		
Valve Size	CI or BRZ valves	DI, CS, SS valves
1-1/2" & 2"	140	200
Torque for spring housing bolts (in/lbs)		
Valve Size	Torqu (in/lbs)	
1-1/2" & 2"	170	170



JORDAN VALVE

3170 Wasson Road • Cincinnati, OH 45209
 Phone 513-533-5600 • Fax 513-871-0105
 Phone Toll-Free:
 800-543-7311 (USA) • 800-354-0305 (Canada)
 E-Mail: info@richardsind.com
 URL: www.jordanvalve.com