



3170 Wasson Road • Cincinnati, OH 45209 USA  
Phone 513-533-5600 • Fax 513-871-0105  
info@richardsind.com • www.jordanvalve.com

## I & M Mark 50 (2½" - 4")

### Installation & Maintenance Instructions for Mark 50 (2½" - 4") Back Pressure Regulator

**Warning:** Jordan Valve Pressure Regulators must only be used, installed and repaired in accordance with these Installation & Maintenance Instructions. Observe all applicable public and company codes and regulations. In the event of leakage or other malfunction, call a qualified service person; continued operation may cause system failure or a general hazard. Before servicing any valve, disconnect, shut off, or bypass all pressurized fluid. Before disassembling a valve, be sure to release all spring tension.

#### Please read these instructions carefully!

Your Jordan Valve product will provide you with long, trouble-free service if it is correctly installed and maintained. Spending a few minutes now reading these instructions can save hours of trouble and downtime later. When making repairs, use only genuine Jordan Valve parts, available for immediate shipment from the factory.

### Installation

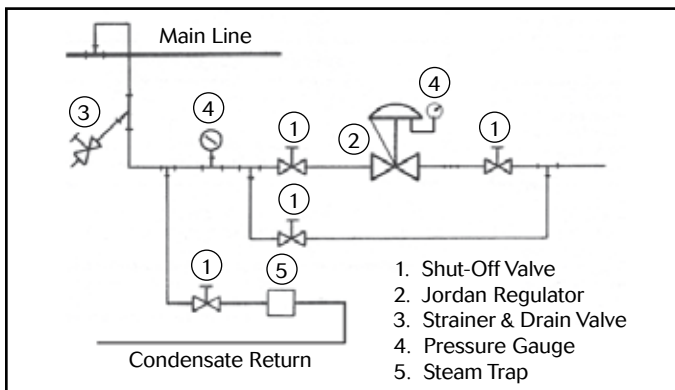

1. To protect the regulator from grit, scale, thread chips, and other foreign matter, all pipe lines and piping components should be blown out and thoroughly cleaned before the regulator is installed.
2. Shut-off valves, pressure gauges, and by-pass piping should be installed as indicated in the diagram to provide easier adjustment, operation, and testing.
3. A line strainer should be installed on the inlet side of the regulator to protect it from grit, scale and other foreign matter. A 0.033 perforated screen is usually suitable. Line strainers are available from Jordan Valve.
4. Install the regulators in the highest horizontal line of piping to provide drainage for inlet and outlet piping, to prevent water hammer, and to obtain faster regulation.
5. The flow arrow on the regulator body must be pointed in the direction of flow. The regulator may be installed vertically or horizontally without affecting its operation.
6. For best control, a minimum 3' 0" straight section of pipe should be installed on either side of the regulator.
7. In hot vapor lines, upstream and downstream piping near the regulator should be insulated to minimize condensation.
8. Expand the outlet piping at least one pipe size if the outlet pressure (downstream) is 25% of the inlet pressure

- or less. A standard tapered expander connected to the outlet of the regulator is recommended.
9. Where surges are severe, a piping accumulator is recommended.

### Control Line

A control line must be installed as follows:

1. Connect one end of a 3/8" control line to the 3/8" NPT tapped opening in the underside of the lower spring housing.
2. Connect the other end in a straight run of pipe 3 to 5 feet upstream from the regulator.
3. Do not locate the control line tap in an elbow, swage, or other changes in configuration of the pipeline where turbulence or abnormal velocities may occur.
4. The control line should be sloped away from the regulator.
5. Install a shut-off valve (not a needle valve) in the control line.
6. Install a pressure gauge in the control line or near the inlet of the regulator to aid in setting the regulator and checking for inlet pressure during maintenance procedures. (There is a 1/4" NPT tapped opening in the lower bonnet.)

### Start-Up Procedure

With the inlet and outlet shut-off valves closed:

1. Throttle the bypass valve so that the pressure to be controlled is maintained near the set point.
2. Fully open the control line shut-off valve.
3. Slowly open the inlet shut-off valve.
4. Open the outlet shut-off valve.
5. Slowly close the bypass valve, but do not close it fully until you are certain that the regulator has control of the system.
6. To change the controlled pressure, turn the adjusting screw clockwise to increase pressure, counter-clockwise to decrease pressure.
7. **WARNING:** Never substitute a longer length adjusting screw. Personal injury and damage to the valve may result.
8. Body-cap cap screws should be retightened to 90 ft./lbs. torque after valve reaches operating temperature.

**PROTECT VALVES WITH LINE STRAINERS**

---

## Trouble Shooting

---

### If You Experience Erratic Control:

- Oversizing causes cycling and hunting and reduces the rangeability of the valve. Make certain that your sizing is correct.
- Steam traps downstream may need attention.
- Safety valve may be jammed open.
- Excessive foreign matter on Seats.
- Valve stroke out of adjustment. Check and readjust if necessary.
- Valve disc may not be moving freely. Check disc guide clearance and clearance of the stem to the bushings.

### If the Valve Will not Operate:

- Diaphragm ruptured.
- Adjusting spring broken. Replace.
- Improper spring setting. Reset.

---

## Maintenance

---

**WARNING: Be sure that there is no pressure in the valve before loosening any fittings or joints. The following steps are recommended.**

1. Close inlet shut-off valve, and by-pass valve.
2. Back off adjusting screw to allow inlet pressure to open seats.
3. Allow pressure to bleed off through downstream piping.
4. When inlet pressure gauge indicates no pressure in the line, close the outlet shut-off valve.
5. Close the control line shut-off valve.

**Refer to the drawings for the proper orientation of the parts and for proper nomenclature.**

---

## Seat Removal

---

**CAUTION: The seats of Jordan regulators are precision-lapped. Maintaining such tolerances is of paramount importance for your assurance of excellent control and tight shutoff. Do not use metallic objects in removing the seats, and care in handling is imperative.**

1. With the valve out of the line, remove the bolts securing the valve cap to the valve body and lift the cap straight up.
2. Lift the disc from the plate and place on a clean surface with the seating side up.
3. Place the valve body on a side. Hold one hand over the plate to receive it and tap lightly on the back of the plate with a soft, blunt object; push the plate out evenly. Place the plate on a clean surface seating side up.
4. Clean out all parts and the body and cap with a good quality solvent. The valve disc and plate may then be cleaned. Place 4/0 polishing cloth or jeweler's cloth on a smooth, flat surface and polish the lapped surfaces. If the parts are scarred, do not attempt to re-lap them, but return them to the factory for repair or replacement.
5. Continue on to the procedures outlined under STROKE ADJUSTMENT.

---

## Diaphragm Replacement

---

1. In removing the diaphragm, you must first remove the valve disc and valve plate. This is outlined under SEAT REMOVAL.
2. Remove the compression of the adjusting spring by rotating the adjusting screw counterclockwise.
3. Remove the upper spring housing. Remove adjusting spring, spring seat and ball bearing.
4. Hold the disc pin with an open end wrench and remove the diaphragm assembly by rotating counterclockwise. The diaphragm assembly consists of the upper diaphragm plate, diaphragm, and lower diaphragm plate.
5. If the diaphragm must be replaced, secure the lower diaphragm plate in the vise. Use a wrench on the hex of the upper diaphragm plate and turn counterclockwise to remove.
6. Remove the diaphragm and replace in reverse order. Tighten. For elastomer diaphragms, clean (degrease) threads and apply one drop of Loctite #290. Thread the parts together and tighten 1/8 - 1/4 turn.
7. Continue on to the procedures outlined under STROKE ADJUSTMENT.

---

## Packing Replacement

---

1. Remove the valve from line.
2. Back off the adjusting screw.
3. Remove the upper spring housing, spring, spring seat and ball bearing.
4. Unscrew the diaphragm assembly.
5. Remove the screws, packing flange and packing follower.
6. Remove the packing. The packing may have a tendency to stick in the packing cavity if the valve has been in service for some time. Movement of the stem may help.
7. The packing retainer and packing spring may be removed, if necessary.
8. Be certain that all packing material has been removed. Check the stem for scratches, etc. Replace if necessary. If the stem must be replaced, remove the seats as outlined under SEAT REMOVAL, and DISC PIN.
9. Replace the packing. Refer to the drawing for proper orientation of the packing.
10. Insert the packing follower.
11. Place the packing flange over the packing follower and insert the screws.
12. Pull the screws down, one turn each, alternating from one to the other until the packing follower is snug against the body and the packing flange is parallel to the body surface.
13. Proceed to the procedures outlined under STROKE ADJUSTMENT.

---

## Disc Pin Replacement

---

1. Remove the valve disc and the valve plate, following the procedure outlined under SEAT REMOVAL.
2. Remove the diaphragm as outlined under DIAPHRAGM REPLACEMENT.
3. Holding the disc pin assembly with an open end wrench, loosen the stem locknut. The stem can now be unscrewed from the disc pin and removed.
4. Remove the disc pin and locknut.

5. Check the condition of and clean all parts. Clean the lower stem bushing. Replace defective parts.
6. Reassemble in reverse order and follow the procedures outlined under STROKE ADJUSTMENT.

## Stroke Adjustment

1. Do not tighten locknut on the stem; run it to the upper end of the thread with the disc pin located at about the center of the threaded section. The valve stroke adjustment is determined by how far the diaphragm assembly is threaded onto the stem. Holding the stem lightly with pliers, thread the diaphragm assembly approximately four turns onto the valve stem and center the disc pin in the valve body. Tighten locknut.
2. Place the plate in the valve body so that the disc pin protrudes through the center slot. The marking "TOP DIRECT" must be toward the diaphragm. Use new gaskets. Follow the same precautions as outlined under SEAT REMOVAL.
3. Temporarily place the disc on the disc pin so that its arrow points (^) toward the diaphragm. Hold parts so they do not fall out.
4. Push the diaphragm assembly down, against the valve body and check the orifice alignment of the disc and plate. The orifices should be fully open and in perfect alignment.
5. If the orifices are not in perfect alignment, rotate the diaphragm assembly counterclockwise to lower the valve disc, or clockwise to raise the valve disc.
6. Remove the disc, turn 180°, and reinstall with the arrow (v) pointing away from the diaphragm. The seats are now fully closed with overlap.
7. Install the upper bonnet and fasten with two bolts 180° apart. If metal diaphragms are used, be certain they are in the recess.
8. Carefully use a tool to pry up on the disc pin, from the opposite end of the valve, and stroke the stem upward until the upper diaphragm plate stops against the housing.
9. The orifices should be fully open and in perfect alignment. If they are not, you will have to remove the upper housing and rotate the diaphragm assembly as in step (5). Then repeat steps (7), (8) and (9).
10. The total stroke of the MARK 50 BPRV is equal to the orifice width plus 1/16" overlap. Consequently, perfect adjustment is required for proper operation.
11. After proper adjustment has been obtained, remove the valve plate and valve disc to eliminate the possibility of damage during topworks reassembly.
12. Place adjusting spring, spring seat and ball bearing on the upper diaphragm plate.
13. In replacing the upper spring housing, make certain that it seats properly in the recess. Torque 9/16" bolts to 100-125 ft./lbs.
14. Reinstall the disc and plate. The wording "Top Direct" on the plate should be on top and the arrow on the disc should point towards the plate wording "Top Reverse."
15. Install the cap onto the body. Align the cap and body flange holes. Install the cap screws and tighten them uniformly to 90 ft./lbs.
16. Adjust adjusting screw to the approximate position it was in.
17. Reinstall and follow START-UP PROCEDURE.

18. Retighten body cap screws after the valve has been reinstalled and has reached operating temperature.

## Torque Procedure for Cap and Spring Housing Bolts

1. Install all bolts hand-tight.
2. Torque the bolts in order of the bolt pattern to a value equal to 1/4 of the recommended torque value.
3. Re-torque each bolt to the recommended value using the same bolt pattern as shown.

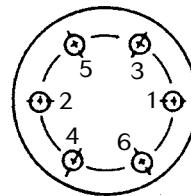

6 bolts  
(or multiples)

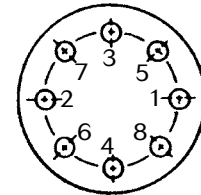

8 bolts  
(or multiples)

Recommended Bolt Torque	
Body to Cap	90 ft./lbs.
Body to Spring Housing (CS/SS Body)	125 ft./lbs.
Body to Spring Housing (CI/DI Body)	85 ft./lbs.
Spring Housing	100 ft./lbs.
Spring Housing (CI/DI Body)	85 ft./lbs.

## Ordering Spare Parts

Use only genuine Jordan Valve parts to keep your valve in good working order. So that we can supply the parts which were designed for your valve, we must know exactly which product you are using. The only guarantee to getting the correct replacement parts is to provide your Jordan Valve Representative with the valve serial number. This number is located on the valve identification tag. If the serial number is not available, the parts needed for your valve might be able to be determined with the following information: Model Number, Valve Body Size, Seat Material and Cv rating, Spring Range and Set Point, Trim Material, Part Name - Number and Quantity (see parts list chart).

NOTE: Without a valve serial number, any parts ordered incorrectly are subject to up to a minimum 25% restock charge when returned.

## Illustration and Parts List

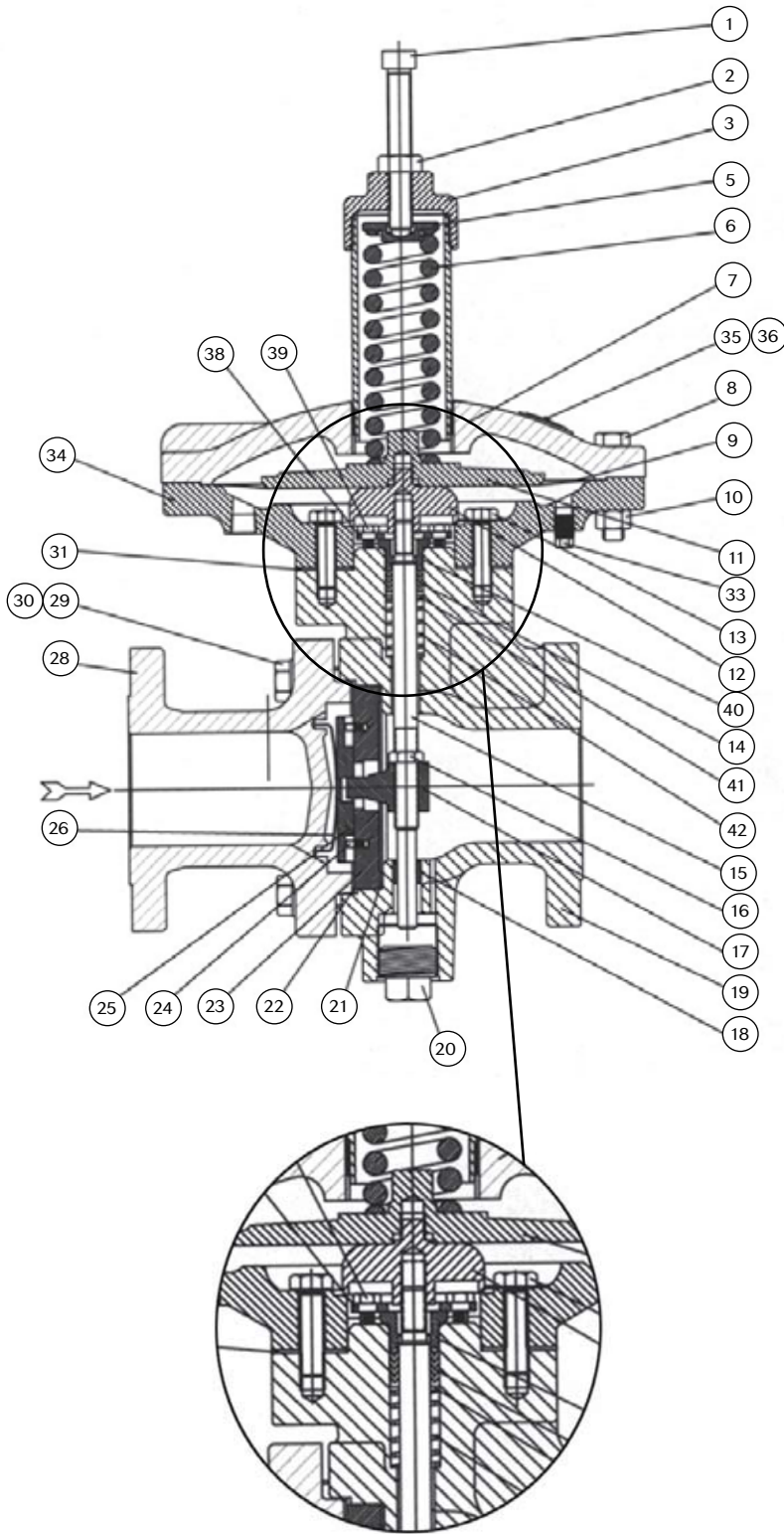

**Exploded View of Packing Area**

Item	Description	Qty.
1	Adjusting Screw	1
2	Lock Nut / Adjusting Screw	1
3	Spring Housing Cap	1
5	Spring Seat	1
6	Spring	1
7	Spring Housing	1
8	Cap Screw (Spring Housing)	12
9	Diaphragm	1
10	Nut (Spring Housing)	12
11	Upper Diaphragm Plate	1
12	Lower Diaphragm Plate	1
13	Cap Screw (Lower Bonnet)	6
14	Packing	1
15	Stem	1
16	Lock Nut (Stem)	1
17	Disc Pin	1
18	Lower Stem Bushing	1
19	Body	1
20	Pipe Plug (Body)	1
21	Gasket (Body)	1
22	Gasket (Cap)	1
23	Plate	1
24	Disc Guide Pin	2
25	Disc	1
26	Disc Spring	1
28	Cap	1
29	Cap Screw	6
30	Lock Washer	6
31	Gasket (Spring Housing/Body)	1
33	Pipe Plug (Lower Bonnet)	1
34	Lower Bonnet	1
35	Name Plate	1
36	Drive Screw	2
37	Index Pin	2
38	Packing Flange	1
39	Bolt (Packing Flange)	2
40	Packing Follower	1
41	Packing Retainer	1
42	Packing Spring	1
*	Recommended Spare Parts	