



# JORDAN VALVE

3170 Wasson Road • Cincinnati, OH 45209 USA  
 Phone 513-533-5600 • Fax 513-871-0105  
 info@richardsind.com • www.jordanvalve.com

## I & M Mark 67 (1/2" – 6")

### Installation & Maintenance Instructions for Mark 67 Pressure Regulators

**Warning:** Jordan Valve pressure regulators must only be used, installed and repaired in accordance with these Installation & Maintenance Instructions. Observe all applicable public and company codes and regulations. In the event of leakage or other malfunction, call a qualified service person; continued operation may cause system failure or a general hazard. Before servicing any valve, disconnect, shut off, or bypass all pressurized fluid. Before disassembling a valve, be sure to release all spring tension.

### Please read these instructions carefully!

Your Jordan Valve product will provide you with long, trouble-free service if it is correctly installed and maintained. Spending a few minutes now reading these instructions can save hours of trouble and downtime later. When making repairs, use only genuine Jordan Valve parts, available for immediate shipment from the factory.

### Ideal Installation

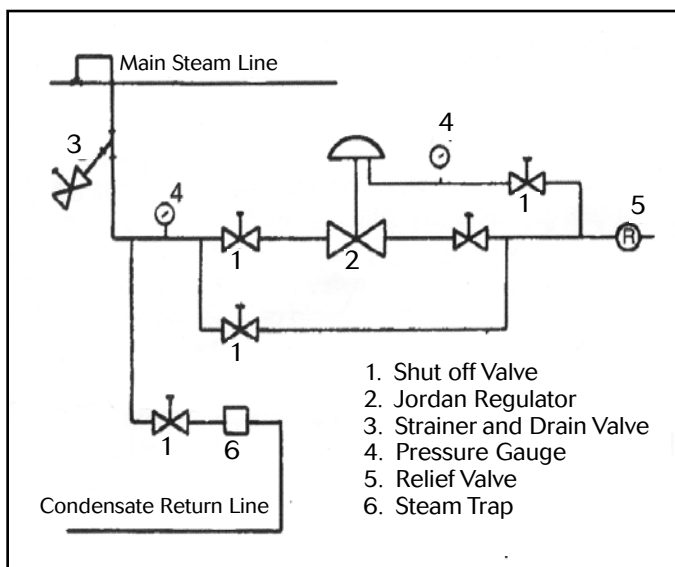

- To protect the valve from grit, scale, thread chips and other foreign matter, ALL pipelines and piping components should be blown out and thoroughly cleaned before the installation process begins.
- Shutoff valves, pressure gauges and by-pass piping should be installed as indicated in the diagram to provide easier adjustment, operation, and testing.
- A line strainer should be installed on the inlet side of the valve to protect it from grit, scale and other foreign matter. A 0.033 perforated screen is usually suitable for this purpose. Line strainers are available from Jordan Valve.
- For best control, 3'0" straight sections of pipe should be installed on either side of the valve.
- In preparing threaded pipe connections, care should be exercised to prevent pipe-sealing com-

pound from getting into pipelines. Pipe-sealing compound should be used sparingly, leaving the two end threads clean. Jordan uses, and recommends, thread sealer Teflon ribbon.

- The flow arrow on the valve body must be pointed in the direction of flow. Ideally, the valve should be installed in the highest horizontal line of piping to provide drainage for inlet and outlet piping, to prevent water hammer, and to obtain faster response.
- If possible, install a relief valve downstream from the valve. Set at 15 psi above the control point of the valve.
- In hot vapor lines, upstream and downstream piping near the valve should be insulated to minimize condensation.
- In gas service, expand the outlet piping at least one pipe size if the control pressure (downstream) is 25% of the inlet pressure or less. A standard tapered expander connected to the outlet of the valve is recommended.
- Where surges are severe, a piping accumulator is recommended.
- On steam control applications, install a steam trap with sufficient capacity to drain the coil or condenser. Be sure to have a good fall to the trap, and no backpressure. Best control is maintained if the coil or condenser is kept dry.

### Control Line

A control line must be installed as follows:

- Connect one end of a 3/8" tubing to the fitting under the diaphragm.
- Connect the other end in a straight run of pipe 3 to 5 feet downstream of the valve.
- DO NOT locate the control line tap in an elbow, swage or other changes in configuration of the pipeline where turbulence or abnormal velocities may occur.
- DO NOT locate the control line tap in vessel, such as a deaerator located immediately downstream of the valve. Locate the tap in the pipeline leading to the vessel.
- The control line should be sloped away from the valve.
- Install a shutoff valve (not a needle valve) in the control line.

7. Install a pressure gauge in the control line or near the inlet of the valve to aid in setting the valve and checking for inlet pressure during maintenance procedures. (There is a 1/4" NPT tapped opening in the lower bonnet.)

---

## Start-Up

---

With the inlet, outlet, and bypass shutoff valves closed, and no pressure in the downstream line:

1. Fully open the control line shut-off valve.
2. Fully open the outlet shut-off valve.
3. Slowly open the inlet shut-off valve.
4. Slowly open the inlet valve just enough to start flow through the valve. Observe the downstream pressure gauge. Increase the downstream pressure slowly by gradually opening the inlet valve.
5. Do not fully open the inlet valve until you are sure that the regulator has control of the system. Usually, the handwheel on the inlet valve will turn freely when this is achieved.
6. To change the controlled pressure, adjust the controlled pressure supplied to the top of the diaphragm.
7. Body and cap bolts should be re-tightened per torque procedures after valve reaches operating temperature.

---

## Trouble Shooting

---

The first step in troubleshooting a piloted pressure regulator is to classify the action of the controlled pressure into one of the following categories:

- A. Under Pressure: Controlled pressure too low; not enough flow or no flow through valve.
- B. Over Pressure: Valve will not close or controlled pressure increases after valve closes.
- C. Pressure Fluctuates: Controlled pressure rises and falls, will not settle out under low loads.

The next step is to determine what could cause the trouble. The third step is to locate and remedy the cause by the process of elimination. Make no assumptions and check the easy ones first. The guide below lists the controlled pressure action, common causes and procedure for checking each cause.

### Controlled pressure action UNDER PRESSURE:

- Valve undersized for application. Check capacity required and valve capacity.
- Line strainer or pilot strainer screen clogged. Blow down strainers or visually check that they are clear.
- Incorrect setting on range spring. Vary the setting and check response.
- Main valve diaphragm ruptured. See action on main valve maintenance.
- Malfunction of other piping components. Check for leaking traps and safety valves, inadvertently opened or closed valves.

### Controlled pressure action OVER PRESSURE:

- Incorrect setting on range spring. Vary the setting and check response.
- Pilot valve or main valve seats leaking. Close inlet shut-off valve, allow downstream pressure to bleed off, close outlet valve and remove loading pressure tubing. Back out adjusting screw on pilot valve until free (both pilot and main valves are now closed.) Crack open inlet shut-off valve - if fluid issues from pilot valve port, the pilot seats are leaking. If the fluid issues from the main valve port, the main valve seats are leaking.
- By-pass shut-off leaking. During period of leakage close outlet shut-off valve, observe downstream pressure gauge.
- Bleed port in main valve clogged/partially clogged. Remove 1/2" NPT pipe plug in upper bonnet to gain access to bleed port and clean bleed port. Follow instructions in section "To Remove Main Diaphragm."

### Controlled Pressure Fluctuates:

- Valve oversized. Check capacity required and valve capacity.

---

## Maintenance

---

**Caution: Ensure that the valve is de-pressurized before loosening any fittings or joints. The following steps are recommended before performing any maintenance on the valve:**

1. Allow pressure to bleed off through the downstream piping. Do not attempt to reverse the flow through the valve by bleeding pressure from the upstream side of the valve.
2. When the pressure gauges indicate that all pressure has been removed from the system, close the outlet shut-off valve and the valve may be serviced.

**Note: Refer to the drawing at the end of this document for description and proper orientation of parts.**

---

## Pilot Valve

---

1. Remove the tubing between the pilot valve and the main valve.
2. Remove the pilot valve by unscrewing the mounting nipple from the main valve.

---

## Remove Pilot Valve Diaphragm

---

1. Release the compression of the range spring by turning the adjusting screw counterclockwise until free.
2. Remove the housing screws (7), spring housing (3), spring guide (4), range spring (5), upper diaphragm plate (6), and diaphragm (8).

---

## Remove Pilot Valve Seats

---

1. Release the bottom cap (15), the return spring (16), plug (17), stem (11), and strainer (not shown) will

- come out.
- 2. Unscrew the seat (13). Lapping is recommended for replacement pilot seats.
- 3. Assemble the valve in reverse order.

---

## Main Valve

---

It is necessary to remove the main valve from the line only if the main valve seats must be replaced, inspected or adjusted. All other operations can be performed with the valve in the line and without disturbing the stroke adjustment.

---

## Valve Seats

---

### A. Disassembly

The sliding Gate Seats of Jordan Valves are lapped to light band flatness. Maintaining such tolerances is of paramount importance for our assurance of excellent control and tight shutoff. DO NOT use metallic objects in removing the seats. Care in handling is imperative.

1. Follow the Maintenance procedures to remove the valve from the line.
2. With the main valve out of the line, remove the bolts securing the cap (2) to the body (1) and lift the cap (2) straight up.
3. Lift the disc from the plate and place on a clean surface with the seating side up.
4. Place the valve body on side. Hold on hand over the plate to receive it and tap lightly on the back of the plate with a soft, blunt object; push the plate out evenly. Place the plate on a clean surface seating side up.

NOTE: on 1/2" - 1-1/4" models, disc guide will also be removed, and on 2-1/2" - 6" models, a disc spring will be located in the cap.

---

## Remove Main Valve Diaphragm & Disc Pin

---

1. Remove the bottom cap. The spring and spring guide will come out with it.
2. Disconnect the loading pressure tubing from the upper bonnet, remove the bonnet bolts and upper bonnet.
3. Lift out the diaphragm assembly consisting of the diaphragm retainer, stroke stop shim (2-1/2" or 3" valve size only,) diaphragm and diaphragm plate.
4. Fasten hub of diaphragm plate in a vise and unscrew diaphragm retainer. Remove stroke stop shim (where used) and diaphragm(s). Only one diaphragm used on 1/2" - 1-1/4" sizes.
5. To remove stem and disc pin, hold the disc pin with a wrench and loosen the locknut, unscrew the stem.
6. Assemble valve in the reverse order of above, following the procedure for stroke adjustment outlined below.

---

## Main Valve Stroke Adjustment

---

1. Do not tighten locknut on the stem; run it to the upper end of the thread with the disc pin located at about the center of the threaded section.
2. Place the plate and disc in the valve body so that the disc pin protrudes through the center slot in plate and engages the disc. Use the following as a guide to properly install the plate and disc:  
 1/2" - 1-1/4" VALVE SIZES: The "V" stamp on the side of the valve body locates the position of the index pin hole in the face of the plate. The arrow which is stamped on the disc should point to the index pin hole. (Since the disc can be rotated 180° in some sizes without affecting the stroke adjustment, there may be no arrow on the disc.) Place disc guide over plate and disc so index pin matches.  
 1-1/2" and 2" VALVE SIZES: Place the disc on the plate and install the disc guide screws. Tighten the screws but make sure that they do not bind the disc against the plate. Place the assembly in the valve body so that the orifices will be open when the disc is stroked down. (With wording "TOP REVERSE" on plate at the top nearest diaphragm.) Engage the disc with the disc pin and check to be sure that the plate seats solidly against the shoulder in the valve body. Rotate the assembly slightly to align the disc screws with the vertical centerline of the valve. The arrow on the disc should be pointing up to the working "TOP REVERSE" on the plate.  
 2-1/2" - 6" VALVE SIZES: The plates are stamped on the backside with the wording "TOP DIRECT" and "TOP REVERSE" to indicate their proper position in the valve body. The wording "TOP REVERSE" is at the top, nearest the diaphragm and the engraved arrow on the disc always points to the wording "TOP REVERSE" on the plate. Check that the index pins in the valve body engage the plate to align the plate in the body.
3. Place the diaphragm assembly on the stem with the diaphragm in its recess in the lower bonnet. Hold the diaphragm assembly firmly against the stop in the lower bonnet and push on the bottom of the stem so that it fully enters the socket in the diaphragm's retainer. In this position, the disc should be in its lowermost position with the orifices of the disc and plate fully aligned. If the orifices are not fully aligned, rotate the stem clockwise to move the disc up, or counterclockwise to move the disc down.
4. When the orifices are perfectly aligned; remove the disc and plate, and lock the locknut on the stem against the disc pin. Replace the disc and plate and recheck the orifice alignment.

## Series 67 Pilot Valve

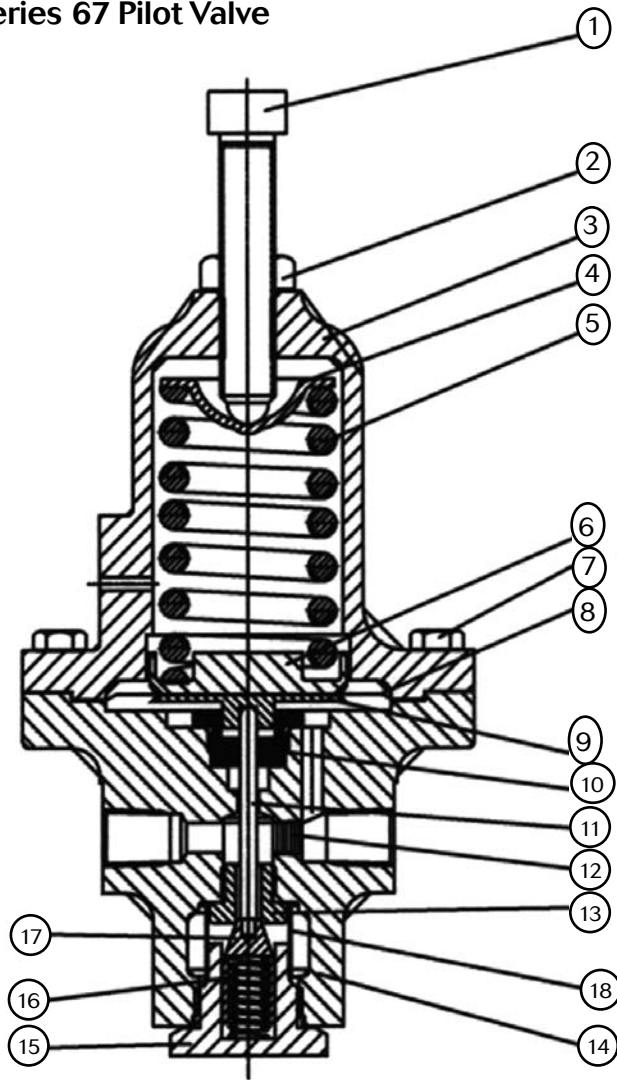

Item	Description
1	Adjusting Screw
2	Jam Nut
3	Spring Housing
4	Spring Guide
5	Range Spring
6	Upper Diaphragm Plate
7	Hex Head Cap Screw
8	Preformed Diaphragm (2 each)
9	Lower Diaphragm Plate
10	Stem Guide
11	Stem
12	1/8" Flush Plug
13	Orifice (Seat)
14	Body
15	Body Cap
16	Return Spring
17	Plug
18	Strainer

## Torque Procedure for Cap & Spring Housing Bolts

1. Install all bolts and hand-tight.
2. Torque the bolts in order of the bolt pattern to a value equal to  $\frac{1}{4}$  of the recommended torque value.
3. Re-torque each bolt to the recommended value using the same bolt pattern as shown.

## Bolt Pattern / Torqueing Sequence

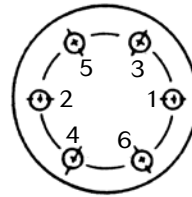

6 bolts  
(or multiples)

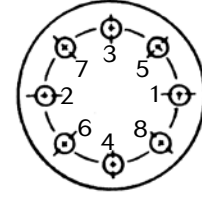

8 bolts  
(or multiples)

## Torque Value

1/2" - 2"	Body/Cap: 200 in/lbs for CS, SS; 150 in/lbs for DI/BRZ Upper Bonnet: 240 in/lbs Pilot Dome: 350 in/lbs
2-1/2" - 6"	Body/Cap: 1080 in/lbs (90 ft/lbs) Upper Bonnet: 240 in/lbs Pilot Dome: 350 in/lbs

## Illustration and Parts List

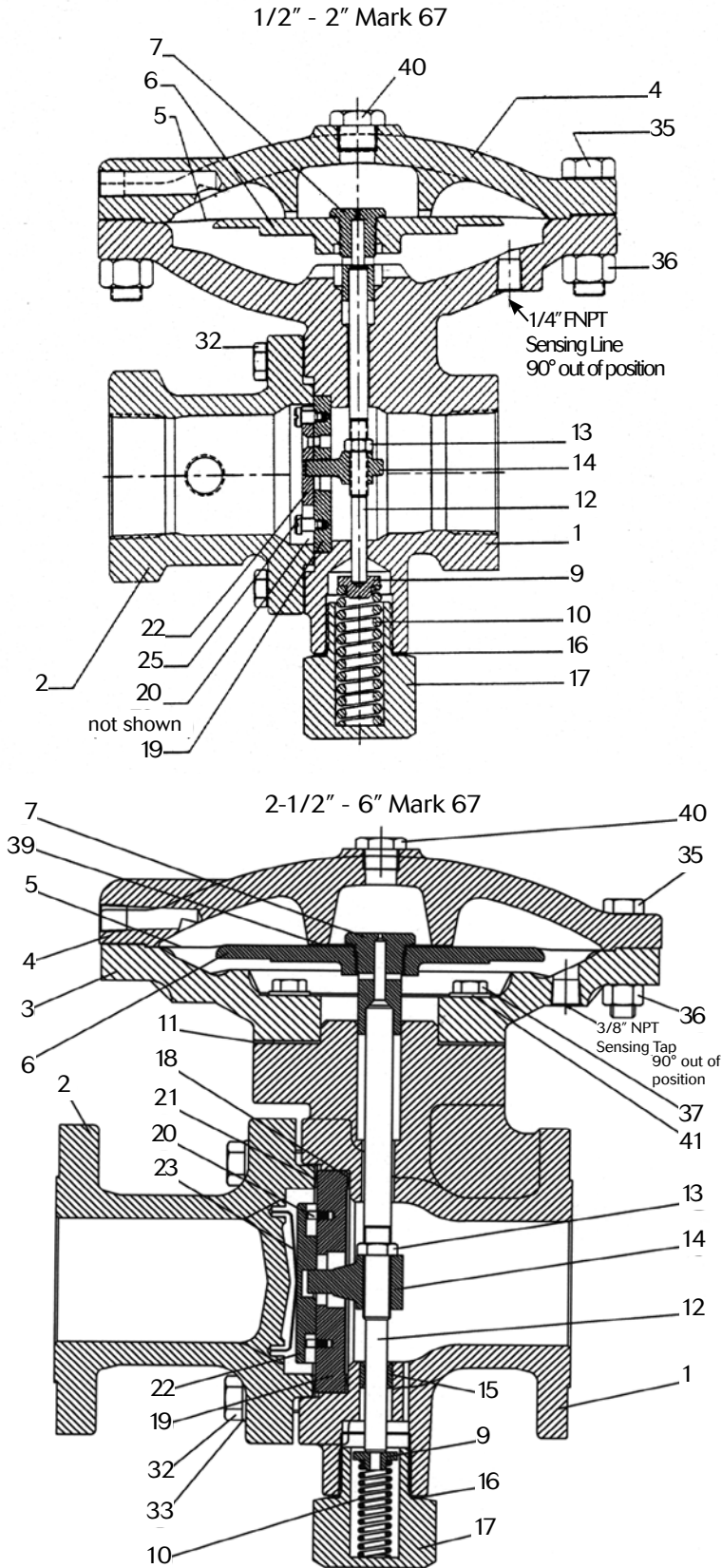

ITEM	DESCRIPTION
1	Body
2	Cap
3	Lower Case (2-1/2" to 6" only)
4	Upper Case
5	Diaphragm
6	Diaphragm Plate
7	Diaphragm Retainer
9	Spring Seat
10	Return Spring
11	Gasket (Lower case) (2-1/2 - 6" only)
12	Stem
13	Locknut
14	Disc Pin
15	Stem Bushing
16	Gasket (Bottom Cap)
17	Bottom Cap
18	Gasket (Body)
*19	Plate
20	Guide Pin (not on 1-1/2" and 2")
21	Gasket (Cap) (2-1/2" to 6" only)
*22	Disc
*23	Disc Spring (2-1/2" to 6" only)
25	Disc Guide Screw (1-1/2" and 2")
32	Cap Screw
33	Lock Washer (2-1/2" to 6" only)
35	Bolt
36	Nut
37	Cap Screw (2-1/2" to 6" only)
39	Stroke Stop Shim (2-1/2" to 3" only)
40	Pipe Plug
41	Lock Washer
*	Recommended Spare Parts