



JORDAN VALVE

3170 Wasson Road • Cincinnati, OH 45209 USA
 Phone 513-533-5600 • Fax 513-871-0105
 info@richardsind.com • www.jordanvalve.com

I & M Mark 78 Series

Installation & Maintenance Instructions for Mark 78 Control Valves (1/2" – 2")

Warning: Jordan Valve control valves must only be used, installed and repaired in accordance with these Installation & Maintenance Instructions. Observe all applicable public and company codes and regulations. In the event of leakage or other malfunction, call a qualified service person; continued operation may cause system failure or a general hazard. Before servicing any valve, disconnect, shut off, or bypass all pressurized fluid. Before disassembling a valve, be sure to release all spring tension.

Please read these instructions carefully!

Your Jordan Valve product will provide you with long, trouble-free service if it is correctly installed and maintained. Spending a few minutes now reading these instructions can save hours of trouble and downtime later. When making repairs, use only genuine Jordan Valve parts, available for immediate shipment from the factory.

Ideal Installation

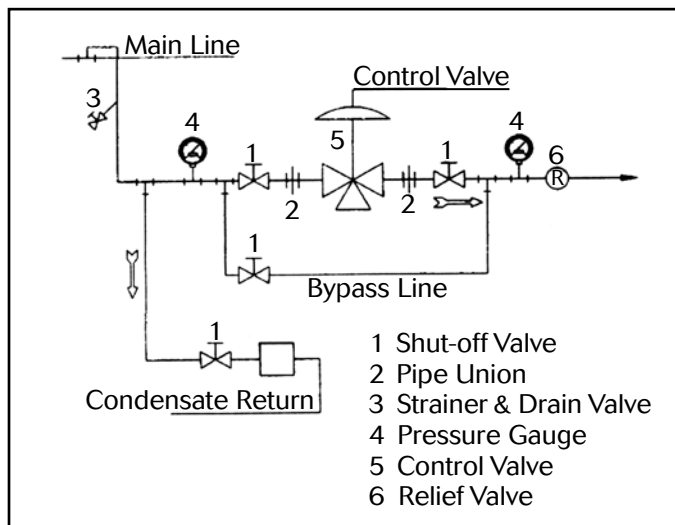

4. A line strainer should be installed on the inlet side of the regulator to protect it from grit, scale and other foreign matter. A 0.033 perforated screen is usually suitable. Line strainers are available for immediate shipment from Jordan Valve.
5. Install the valve in the highest horizontal line of piping to provide drainage for inlet and outlet piping, to prevent water hammer and to obtain faster response.
6. The flow arrow on the regulator body must be pointed in the direction of flow. The valve may be installed vertically or horizontally without affecting its operation.
7. For best control, 3'-0" straight section of pipe should be installed on either side of the valve.
8. In hot vapor lines, upstream and downstream piping near the valve should be insulated to minimize condensation.
9. If possible, install a relief valve downstream from the valve. Set at 15 psi above the control point of the valve.
10. Expand the outlet piping at least one pipe size if the controlled pressure (downstream) is 25% of the inlet pressure or less. A standard tapered expander connected to the outlet of the valve is recommended.
11. Where surges are severe, a piping accumulator is recommended.

Installation

1. To protect the valve from grit, scale, thread chips, and other foreign matter, all pipe lines and piping components should be blown out and thoroughly cleaned before the valve is installed.
2. Shutoff valves, pressure gauges, and bypass piping should be installed as indicated in the diagram to provide easier adjustment, operation, and testing.
3. In preparing threaded pipe connections, care should be exercised to prevent pipe sealing compound from getting into the pipe lines. Pipe sealing compound

Start-Up

1. Be sure that the action of the control valve and of the controller are such as to give the desired results. See "Reversing Action" to change the valve action if necessary.

If an increase in pressure or temperature must	And the action of the valve is	Then the action of the controller must be
close valve	air to close	direct
close valve	air top open	reverse
open valve	air to close	reverse
open valve	air to open	direct

- The control valve has been pre-set by Jordan Valve. However, finer adjustments may be required to compensate for pressure drop conditions of the application.
- With the inlet, outlet and bypass shutoff valves closed, and no pressure in the downstream line, fully open the shutoff valve. Slowly open the inlet valve just enough to start flow through the control valve. Increase flow gradually by slowly opening the inlet shutoff valve. Do not fully open the inlet valve until you are sure that the controller and control valve have control of the system. Usually, the handwheel on the inlet valve will turn freely when this point is reached.
- To shut off the line fluid, close the inlet shut-off valve first, then the outlet shut-off valves.

Maintenance

To reduce maintenance time, refer to proper figure and follow steps indicated below for applicable maintenance operation.

Proposed Maintenance Procedure	Follow Steps...
Renewing stem packing	Packing replacement
Valve disassembly, inspecting parts, replacing plug or seat ring	Valve disassembly
Valve reassembly	Valve reassembly
Actuator spring preload adjustment	Actuator spring preload adjustment
Actuator maintenance	Actuator maintenance
Changing valve action	Reversing action

Packing Replacement

Renew valve plug stem packing if control valve has been in service beyond normal maintenance, and packing shows signs of wear. Wear will be indicated by leakage which cannot be corrected by minor tightening of packing flange.

An additional packing ring can be installed to overcome minor leakage without dismantling the control valve or breaking valve plug connection.

- Disassemble control valve as far as necessary for the work required (see "Valve Disassembly"). Remove

packing. Clean valve plug stem (4) and packing box thoroughly. Polish valve plug stem (4) with crocus cloth. Use approved non-residue-forming solvent for cleaning. Wipe dry with clean cloth.

- Insert a new set of packing (6) in packing box. Press each ring down in place with a tube as it is installed.
- After packing is installed, assemble packing follower (12), packing nut (14) to bonnet (2).

Valve Disassembly

- Close inlet and outlet stop valves. Operate system bypass if necessary.
- Following instructions according to valve action:
 - Direct Acting Actuator (ATC):** shut off operating medium and relieve pressure from diaphragm by disconnecting tubing at diaphragm case. To remove the actuator from the valve body assembly: loosen the two stem nuts (20) and move down the stem (4). Lock the nuts together and, using a wrench on these nuts and the flats on the actuator stem (24), turn the valve stem out of the actuator stem threads until it disengages. Loosen and remove the four yoke bolts (16) and lift the actuator assembly from the bonnet (2).
 - Reverse Acting Actuator (ATO):** apply air pressure to actuator to lift plug off of seat. To remove the actuator from the valve body assembly: loosen and remove the four yoke bolts (16). Loosen the two stem nuts (20) and move down the stem (4). Lock the nuts together and, using a wrench on these nuts and the flats on the actuator stem (24), turn the valve stem out of the actuator stem threads until it disengages. Lift the actuator assembly from the bonnet (2).
- Loosen packing nut (14).
- Remove bonnet (2) from the body (1).
- Remove support washer (7) [on soft seated valves in 1/2" – 3/4" & 1-1/2" sizes only], seal (6) [soft seated valves only], seat (5), and seat o-rings (8) from the body.
- Remove plug/stem (4) from the bonnet (2).
- Remove packing nut (14), packing follower (12) and packing (13).
- Cleaning: clean all parts with an approved, non-residue-forming solvent. Remove encrusted materials with crocus or very mild aluminum oxide cloth. Clean packing box thoroughly.
- Inspect all parts including plug, seal and seat. Replace any badly worn or damaged parts.
- Replacing Seats (*Hard Seated Valves Only*): if seat is badly worn or damaged, it should be replaced. Very minor cuts on the seating surface, however, may be lapped out. NEVER lap to the extent that the valve plug becomes grooved.
 - Lapping in Valve Plug & Seat Ring: replace valve plug (4) in bonnet (2). Apply superfine lapping compound to valve plug seating surface at several points. Re-

place seat o-ring (8) and seat (5) in body (1). Reassemble bonnet (2) to body (1). Use stem to align seat to plug in the body. Lap valve plug and seat ring in until a fine continuous ring of contact has been made on both surfaces. DO NOT lap until a ridge is formed in valve plug seating face. A few turns are sufficient. When lapping, turn valve plug in short arcs and occasionally lift valve plug off seat ring and turn in 1/4 turn to maintain even distribution of lapping compound. When lapping is completed, disassemble bonnet from body and remove all traces of lapping compound.

Valve Reassembly

1. Place seat o-ring (8) on seat (5) [use small amount of grease to hold these parts together] and place in valve body (1). Place cage (46) and spacer (10) into body.
2. Assemble stem/plug (4) to bonnet (2).
3. Place support washer (7) [1/2" – 3/4" & 1-1/2" only] and seal (6) [soft seated valves only] on end of bonnet (2), being careful to get these parts properly seated in the bonnet end. A small amount of grease will hold the support washer and seal in place while assembling the bonnet to the body.
4. Reassemble the bonnet (2) to the valve body (1) making sure that seat o-ring (15), spacer (10), cage (46), seat (5), seal (6), and support washer (7) are properly in place.

Important: Be sure to tighten bolts evenly and securely.

5. Install a new set of packing (13) as described in "Packing Replacement".
6. Reassemble two stem nuts (20) and travel indicator (19) to valve stem (4).
7. Insert threaded end of bonnet (2) through hole in yoke (3) and secure actuator to the body with four bolts (16). Tighten to 10 ft/lbs.
8. Lift the valve stem (4) and thread it into the actuator stem (24) at least one diameter. Adjust actuator spring preload as described in the following section.

Actuator Spring Preload Adjustment (Starting Pressure)

Caution: Do not apply more than 50 psig to actuator

- Direct Acting Actuator (ATC): Actuator spring preload adjustment can be made either with or without pressure in valve body. Once correct compression is made, no further adjustment is necessary.
- Reverse Acting Actuator (ATO): Note: ATO 3-15 psig rated valves are bench set at the factory at 5-17 psig. Please insure that any I/P utilized with this control valve is capable of 17 psig output to ensure full valve travel. If desired, the range may be changed to suit your needs by following the instructions below. The valve plug is closed against upward fluid thrust

by actuator spring force. Total compression placed on actuator spring must be sufficient to provide the reload plug force required to close the valve. If preload adjustment is made with no pressure in valve body, then, when the control valve is placed in operation, body, then, when the control valve is placed in operation, additional compression must be placed on the spring to provide valve closure force. With proper adjustment, valve will close tightly and will not begin to open until the preload pressure is exceeded.

■ Adjusting Spring Preload:

1. Loosen two stem nuts (20), move down the stem (4) and lock two stem nuts together.
2. Connect control air supply line with a pressure gauge to the diaphragm case fitting (21B for ATO or 37B for ATC).
3. **Direct Acting Actuator (ATC 3-15 Range):**
Note: If range is other than 3-15, adjust preload to low end of range.

Adjust spring preload until valve starts to close when 3 psig air pressure is supplied to the actuator diaphragm. *If there is valve movement at less than 3 psig:* thread the valve stem (4) into the actuator stem (24), wrenching on locked stem nuts (20) and flats on actuator stem (24) to increase the spring preload. *If there is no movement at 3 psig:* thread the valve stem (4) out of the actuator stem (24) to decrease the spring preload.

Reverse Acting Actuator (ATO 3-15 Range)

Jordan control valves rated 3-15 (ATO) are bench set at the factory at 5-17 psig. Please insure that any I/P utilized with this control valve is capable of 17 psig output to ensure full valve travel. If desired, the range may be changed to suit your needs by following the instructions. In general, adjust 3-15 range to 5 psig; all other ranges are adjusted to the low end of the range.

Adjust spring preload until valve just starts to open when 5 psig air pressure is supplied to the actuator diaphragm. *If there is valve movement at less than 5 psig:* thread the valve stem (4) out of the actuator stem (24), wrenching on locked stem nuts (20) and flats on actuator stem (24) to increase the spring preload. *If there is no valve movement at 5 psig:* thread the valve stem (4) into the actuator stem (24), wrenching on locked stem nuts (20) and flats on actuator stem (24) to decrease the spring preload.

Note: alternately adjust preload and check pressure to start valve movement by raising pressure to 5 psig (or pressure required to start movement) until proper adjustment is attained.

4. After proper spring preload has been attained, loosen two stem nuts (20), thread them up the stem (4) and lock against the end of the actuator stem (24). If necessary, adjust the position of the travel indicator (17) by loosening two screws (18) and moving the travel indicator until it is properly aligned with the indicator washer (19).

Note A: a control valve which has been adjusted to provide 3 psig starting pressure plus valve closure force (with pressure in body) will have a considerably higher start-pressure than 3 psig, when tested at 0 body pressure.

Note B: air pressures quoted are relative. Actual pressures required in operation may vary with pressure drop conditions existing and/or actuator springs used.

Actuator Maintenance

■ Disassembly and Inspection of Actuator

1. Close inlet and outlet stop valves. Operate system bypass, if necessary. Remove the actuator as described in "Valve Disassembly", Step 3.
2. Remove the nuts (39) and bolts (38) which hold the upper actuator case (37A) to the lower actuator case (21A) and remove the upper actuator case.
3. **Direct Acting Actuator (ATC):** remove the actuator stem bolt (35) and lift the seal washer (33), diaphragm (32), diaphragm plate (31), and spacer (30) [on 55M actuator only] for the actuator stem. Remove the actuator stem (24). To check the stem o-ring (27), unscrew the gland nut (25) from the gland (26) and remove the stem o-ring from the end of the actuator.
Reverse Acting Actuator: remove springs (36) from diaphragm plate (31). Remove the actuator stem bolt (35) and lift spacer (30) [on 55M actuators only], diaphragm plate (31), diaphragm (32), seal washer (33) and seal ring (34) from the actuator stem (24). Remove the actuator stem (24). To check the stem o-ring (27), unscrew the gland nut (25) from the gland (26) and remove the stem o-ring from the end of the gland.
4. Clean all parts with an approved, non-residue-forming solvent. Remove encrusted material with crocus or very mild aluminum oxide cloth. Inspect all parts for excessive wear and/or damage. Replace any worn or damaged parts.

■ Reassembly of Actuator

After all parts have been thoroughly cleaned and inspected, reassemble the actuator.

1. **Direct Acting Actuator (ATC):** insert the actuator stem (24) through the gland (26), greasing stem o-ring (27), if available, before inserting the actua-

tor stem. Place the springs (36) in the lower actuator case (21A). Place the diaphragm plate (31) on the springs so that the stamped bosses are nested in the springs. Install the diaphragm (32) so the bolt holes line up with the bolt holes in the lower actuator case. Place the seal washer (33) on the diaphragm and bolt together with the actuator stem bolt (35) and with seal ring (34) and tighten.

- Reverse Acting Actuator (ATO):** lightly grease the stem o-ring (27) and install in the c'bore in the gland (26). Thread actuator stem (24) through the gland. Assemble the spacer (30) [55M actuators only], diaphragm plate (31), diaphragm (32), seal washer (33) and seal ring (34) to stem actuator bolt (35) and thread into the actuator stem (24). Line up the bolt holes in the diaphragm with the holes in the lower diaphragm case. Place the springs (36) on the diaphragm plate nested over the punched bosses.
2. Place the upper actuator case (37A) on the diaphragm, lining up the bolt holes.
 3. Replace four bolts (38) and nuts 90° apart and tighten finger-tight. Replace the remainder of the bolts and nuts and tighten evenly and alternate across the actuator case.
 4. Thread the valve stem (4) into the actuator stem (24) and adjust the spring preload as described previously ("Actuator Spring Preload Adjustment").

Reversing Action

Changing the valve action from direct to reverse acting or from reverse to direct acting.

The action of the Mark 78 control valve is reversed by reversing the action of the actuator.

1. Disassemble the actuator as described in "Actuator Maintenance".
2. Reassemble the actuator with the desired action. Refer to "Actuator Maintenance".

Ordering Parts

Use only genuine Jordan Valve replacement parts!

Replacement parts for this Jordan Valve product are kept in stock for immediate shipment. The use of other than genuine Jordan Valve parts may impair their ability to serve you. Jordan parts are held to close tolerances to eliminate field machining and grinding (on plugs and rings) or reaming (plug guide bushings).

When ordering parts, refer to the drawings at the end of this document and reference the appropriate part name.

When ordering replacement parts, please supply the following information: valve model name, serial number (if available), part name, actuator size, body material, valve action and Cv.

Troubleshooting

Erratic Control:

1. Oversizing causes cycling or hunting - recalculate size required.
2. Undersizing causes control setting to drop under peak loads.
3. Steam traps downstream may need reconditioning.
4. Safety relief valve may be jammed open.
5. Excessive foreign matter may be lodged in seats.
6. Valve stroke may be out of adjustment.
7. Valve plug may not be moving freely.
8. Inlet pressure may be too low.

Insufficient Flow:

1. Check shutoff valves to be sure they are fully open.
2. Check pressure on upstream side (install a pressure gauge on the upstream side).
3. Blow down strainers.
4. Clean all traps and be sure they are in good working order. If the return line from the trap is cool, the steam coil may be clogged.

Overriding:

1. Usually caused by scale or foreign matter holding the plug open - inspect and clean or replace.
2. May be caused by failure of the diaphragm - replace diaphragm as needed.
3. May be caused by too high a spring setting - adjust if necessary.
4. May be caused by insufficient instrument output pressure.

Leakage or Erratic Regulation:

1. Excessive pressure drop - reduce with pressure regulating valve.
2. Plug may be binding.
3. There may be excessive foreign matter in seat.

Illustration & Part List

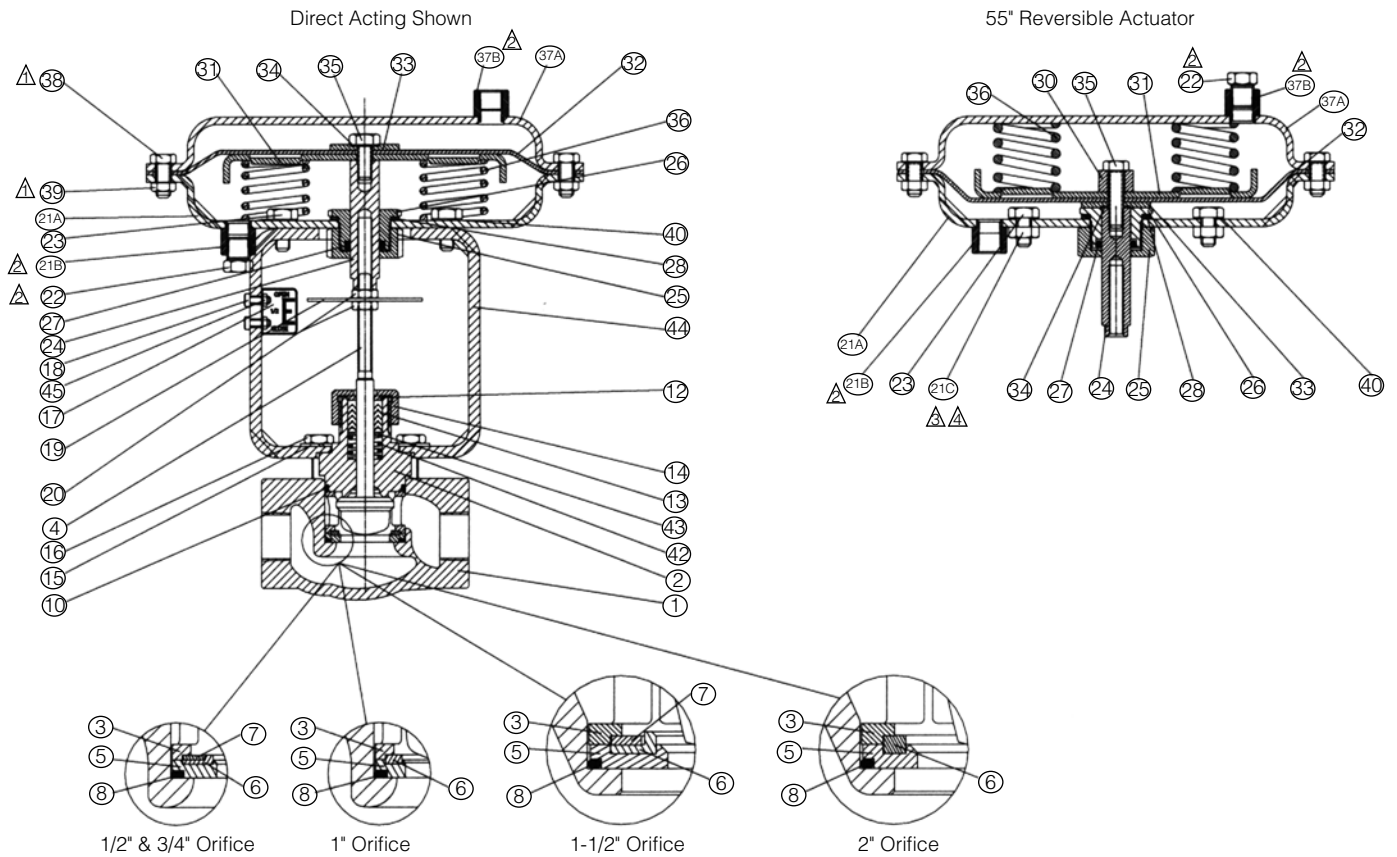

- △ 35M actuator has 8 nuts and bolts, 55M actuator has 16 nuts and bolts, 85M actuator has 22 nuts & bolts
- △ Shown rotated 90° from true position
- △ 2 nuts for 1/2" - 1", 6 nuts for 1-1/2" - 2", 1/2" - 1" has 4 tapped holes in yoke
- △ Shown rotated 30° from true position

Item	Description	Qty	Item	Description	Qty
1	Body	1	23	Bolts (Actuator/Yoke)	6
2	Bonnet	1	24	Actuator Stem	1
3	Cage	1	25	Gland Nut	1
4	Stem & Plug Assembly	1	26	Gland	1
5	Seat	1	27	O-Ring (Stem)	1
6	Seal (Soft Seat only)	1	28	Gland Gasket	1
7	Support Washer (1/2", 3/4" & 1-1/2" only)	1	30	Spacer (55in ² actuator)	1
8	Seat O-Ring	1	31	Diaphragm Plate	1
10	O-Ring (Bonnet)	1	32	Diaphragm	1
12	Packing Follower	1	33	Seal Washer	1
13	Packing	5	34	Seal Ring (Seal Washer)	1
14	Packing Nut	1	35	Bolt (Actuator Stem)	1
15	Washer (Body Bolts)	4	36	Springs (3-15)	6
16	Body Bolts	4	37	Upper Case Assembly	1
17	Travel Scale	1	37A	Upper Case	1
18	Screws (Travel Scale)	2	37B	Bushing	1
19	Indicator Washer	1	38	Bolts	△
20	(Stem) Nut	2	39	Nuts	△
21	Lower Case Assembly	1	40	Seal Washer (Actuator)	6
21A	Lower Case	1	42	Packing Spring	1
21B	Bushing	1	43	Washer	1
21C	Nuts (1/2" - 1" only)	△	44	Yoke	1
22	Vent Plug	1	45	Nuts Travel Scale	2