

# Mark 508 Series

CRN Registration Number Available

## Gas Back Pressure Regulators

**3/4" – 1-1/4"**

The Mark 508 Gas Back Pressure Regulator is the ideal valve for low back pressure gas services.

The Mark 508 works in conjunction with the Mark 608, in a low pressure tank blanketing valve system. The Mark 508 can be used to vent gas from the tank to prevent the blanketing pressure from rising to a level that could damage the tank while maintaining a small constant flow to keep the blanket fresh. During filling, this regulator will be required to open wide to allow enough gas to escape as the vapor space in the tank grows smaller. To size properly, the rate of fill must be known so that a regulator can be chosen based on its ability to relieve the required amount of gas while sustaining desired blanketing pressure. The Mark 508 will also work well in any other type of low back pressure application.

### FEATURES

- Body rating up to 150 psi (10,3 bar)
- Rugged, heavy-duty design – emergency outlet pressure may reach 100% of inlet pressure without damaging valve
- 360° body orientation – valve can be installed in any position, and can be easily repositioned while in-line
- Easy maintenance – seat and plug can be inspected without removing body from the line
- Completely self-operated – no external power source required
- Tight shutoff – soft elastomer plug provides ANSI Class VI shutoff

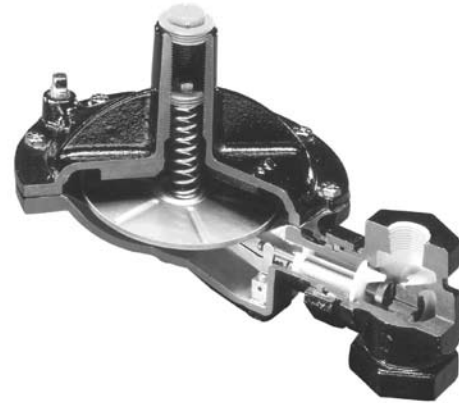

### SPECIFICATIONS

**Sizes:** 3/4" (DN20), 1" (DN25), 1-1/4" (DN32)

#### End Connections

- Threaded – NPT, SWE, BSPT, BSPP
- Flanged – 150#, 300#, PN16, PN40

#### Materials

- Body & Housing: Ductile Iron, Carbon Steel (A216, WCB), Stainless Steel (A351/CF8M)
- Seat: Brass (DI body); Stainless Steel (CS/SS body)
- Plug: Brass and Buna-N/Nylon (DI body); Stainless Steel and Viton (CS & SS body)
- Diaphragm: Buna-N/Nylon (DI body); Viton (CS & SS body)
- Aspirator Tube: Acetal
- Actuator Cases: matches body material
- Actuator Diaphragm: Buna-N for DI bodies, Viton for CS and SS bodies

**Service:** air or gas

**Shutoff:** ANSI Class VI

**Temperature Range:** -20°F (-29°C) to 200°F (93°C)

**Maximum Inlet Pressure:** 150 psi (10 bar)  
**Range**

- 2.0 to 6 inches w.c. (5,0 to 15,0 mbar)
- 3.0 to 11 inches w.c. (7,5 to 27,4 mbar)
- 5.0 to 35 inches w.c. (12,4 to 87 mbar)



Jordan Valve a division of Richards Industries  
3170 Wasson Road • Cincinnati, OH 45209  
513.533.5600 • 800.543.7311 • 513.871.0105 (f)  
info@richardsind.com • www.jordanvalve.com

MARK 508 GAS BACK PRESSURE REGULATOR

**DIMENSIONS (3/4" – 1-1/4") NPT, SWE, BSPT, BSPP ENDS**

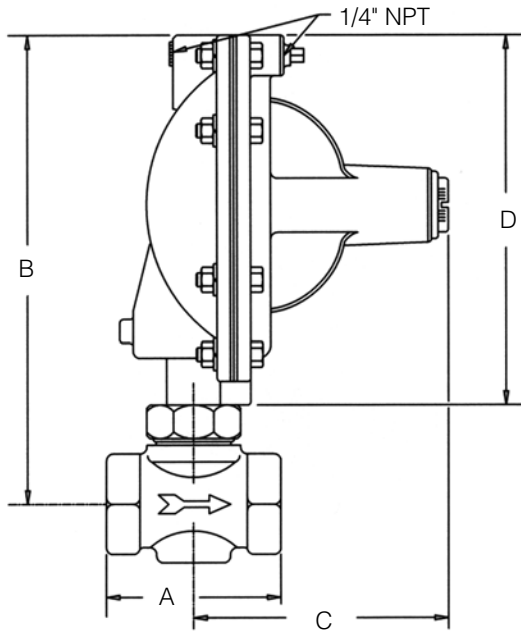

Valve Size	Dimensions (inches)				Weight lbs
	A	B	C	D	
3/4"	3.88	11.31	5.75	9.00	15
1"	3.88	11.31	5.75	9.00	15
1-1/4"	3.88	11.31	5.75	9.00	15

Valve Size	Dimensions (metric)				Weight kgs
	A	B	C	D	
DN20	99	287	146	229	6,8
DN25	99	287	146	229	6,8
DN32	99	287	146	229	6,8

**DIMENSIONS (3/4" – 1-1/4") FLANGED ENDS**

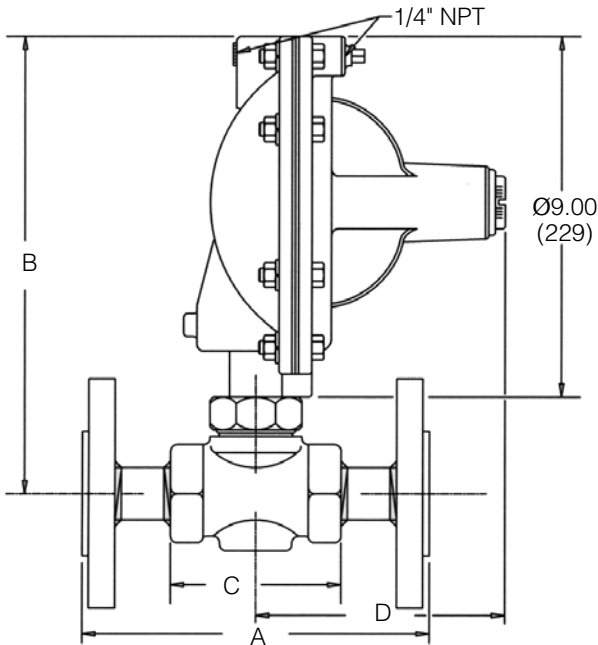

Valve Size	Ends	Dimensions (inches)			
		A	B	C	D
3/4"	150FE	7.25	11.31	3.88	5.75
	300FE	7.50	11.31	3.88	5.75
1"	150FE	7.25	11.31	3.88	5.75
	300FE	7.75	11.31	3.88	5.75
1-1/4"	150FE	7.87	11.31	3.88	5.75
	300FE	8.35	11.31	3.88	5.75

Valve Size	Ends	Dimensions (mm)			
		A	B	C	D
DN20	150FE	184	287	99	146
	300FE	191	287	99	146
DN25	150FE	184	287	99	146
	300FE	197	287	99	146
DN32	150FE	200	287	99	146
	300FE	212	287	99	146

MARK 508 GAS BACK PRESSURE REGULATOR

FLOW CAPACITIES & SIZING

Spring Range	Set Point	Minimum Pressure Build	Outlet Vacuum psig (bar)	Flow of Nitrogen scfh (nm <sup>3</sup> /h)
2 - 6" WC 5,0 - 15,0 mbar	3.0" WC 7,5 mbar	2.3" WC 5,7 mbar	0 (0)	368 (10)
			-2.5 (-0,2)	1253 (35)
			-5.0 (-0,3)	1582 (45)
	5.0" WC 12,5 mbar	2.3" WC 5,7 mbar	0 (0)	406 (12)
			-2.5 (-0,2)	1199 (34)
			-5.0 (-0,3)	1505 (43)
3 - 11" WC 7,5 - 27,4 mbar	6" WC 15,0 mbar	2.9" WC 7,2 mbar	0 (0)	456 (13)
			-2.5 (-0,2)	1233 (35)
			-5.0 (-0,3)	1540 (44)
	11" WC 27,4 mbar	2.9" WC 7,2 mbar	0 (0)	569 (16)
			-2.5 (-0,2)	1272 (36)
			-5.0 (-0,3)	1569 (44)
5 - 35" WC 12,5 - 87,2 mbar	18" WC 44,8 mbar	8.0" WC 19,9 mbar	0 (0)	708 (20)
			-2.5 (-0,2)	1245 (35)
			-5.0 (-0,3)	1493 (42)
	30" WC 74,7 mbar	8.0" WC 19,9 mbar	0 (0)	856 (24)
			-2.5 (-0,2)	1324 (37)
			-5.0 (-0,3)	1552 (44)

ORDERING SCHEMATIC (3/4" – 1-1/4")

Model No	Size	Body Mat'l	1	2	3	4	5	6	7	8

Model	
508	Standard

3 & 4	Range	
	W.C.	mbar
01	2 - 6" W.C.	5,0 - 15,0 mbar
02	3 - 11" W.C.	7,5 - 27,4 mbar
03	5 - 35" W.C.	12,5 - 87,2 mbar
ZZ	Non-Standard	

Size	
075	3/4" (DN20)
100	1" (DN25)
125	1-1/4" (DN32)

5 & 6	
SD	Standard
ZZ	Non-Standard

Body Material	
DI	Ductile Iron
CS	Carbon Steel (WCB)
S6	Stainless Steel (CF8M)

7 & 8	
00	None
03	Clean for Oil-Free Service
ZZ	Non-Standard

1 & 2	
PT	NPT
BT	BSPT
BP	BSPP
SW	FSW
F5	150# FE
F3	300# FE
ZZ	Non-Standard

## 1-1/2" – 2"

The 1-1/2" and 2" size Mark 508 valves are for use on large tank blanketing applications or other low back pressure applications.

In a tank blanketing application, the Mark 508 is used to control the back pressure of the blanketing gas in the tank. Used in conjunction with Jordan's Mark 608 gas regulator, the Mark 508 vents gas from the tank to prevent blanketing pressure from rising to a level that could damage the tank.

The Mark 508 comes standard with an extra large diaphragm to give set point control as low as 2.0" WC (5,0 mbar). In addition, the "S" pattern body design allows for high flow capacity and also gives the option of having bubble tight shutoff.



## FEATURES

- Inlet pressures up to 25 psi (1,7 bar)
- Rugged, heavy-duty design – emergency outlet pressure may reach 100% of inlet pressure without damaging valve
- Easy maintenance – seat and plug can be inspected without removing body from the line
- Completely self-operated – no external power source required
- Tight shutoff – soft elastomer plug provides ANSI Class VI shutoff

## SPECIFICATIONS

**Sizes:** 1-1/2" (DN40) & 2" (DN50)

### End Connections

- Threaded – NPT, BSPT, BSPP
- Flanged – 150#, 300#, PN16, PN40
- Others upon request

### Materials

- Body: Bronze (B61), Carbon Steel (WCB), Stainless Steel (CF8M)
- Trim: 316 Stainless Steel
- Seat: 316 Stainless Steel
- Diaphragm: Buna-N/Nylon, Viton/Nomex and EPDM with Polyester reinforcement
- Seals: Viton, Buna-N and EPDM

**Shutoff:** ANSI Class VI

### Ranges

- 2 to 5 inches w.c. (5,0 to 12,5 mbar)
- 4 to 8 inches w.c. (10,0 to 20 mbar)
- 8 to 28 inches w.c. (20 to 70 mbar)
- 10 to 17 inches w.c. (25 to 42 mbar)
- 14 to 28 inches w.c. (35 to 70 mbar)
- 0.75 to 1 psi (52 to 69 mbar)
- 1 to 2 psi (69 to 138 mbar)
- 1.5 to 3 psi (0,10 to 0,21 bar)
- 3 to 5 psi (0,21 to 0,34 bar)

**Cv Rating:** 37 (43 Kv)

### Pressure Temperature Rating

- 25 psi @ 100°F (1,7 bar @ 37,8°C)
- 25 psi @ 275°F (1,7 bar @ 135°C)

**Maximum Pressure Drop:** 25 psig (1,7 bar)

MARK 508 GAS BACK PRESSURE REGULATOR

**DIMENSIONS (1-1/2" – 2") NPT, SWE, BSPT, BSPP ENDS**

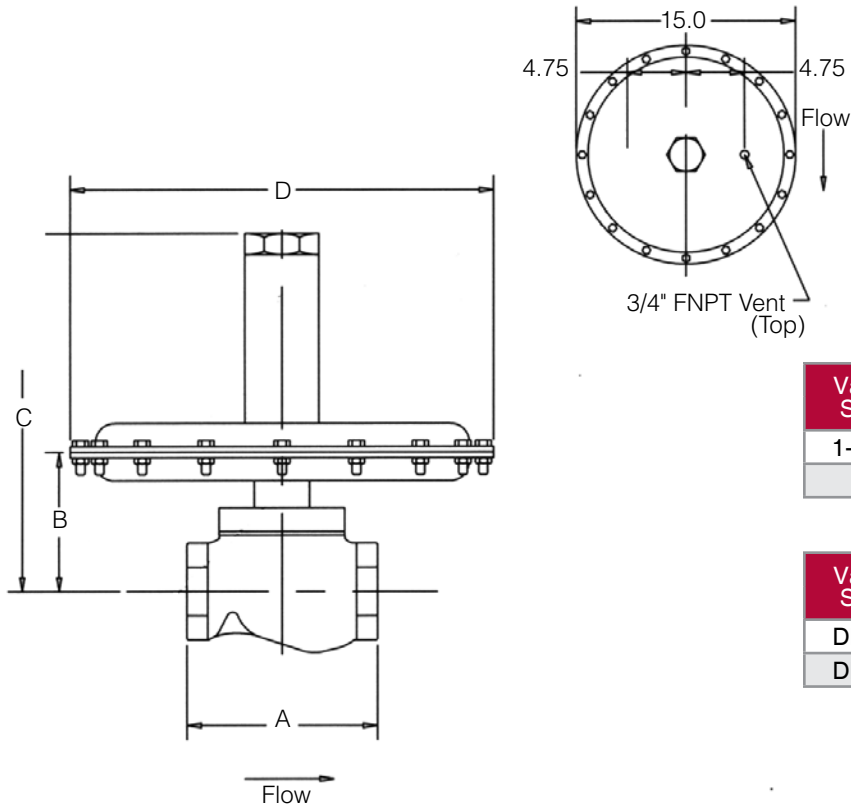

Valve Size	Dimensions (inches)			
	A	B	C	D
1-1/2"	6.75	4.93	12.32	15.0
2"	6.75	4.93	12.32	15.0

Valve Size	Dimensions (metric)			
	A	B	C	D
DN40	171,5	125,2	313	381
DN50	171,5	125,2	313	381

**DIMENSIONS (1-1/2" – 2") FLANGED ENDS**

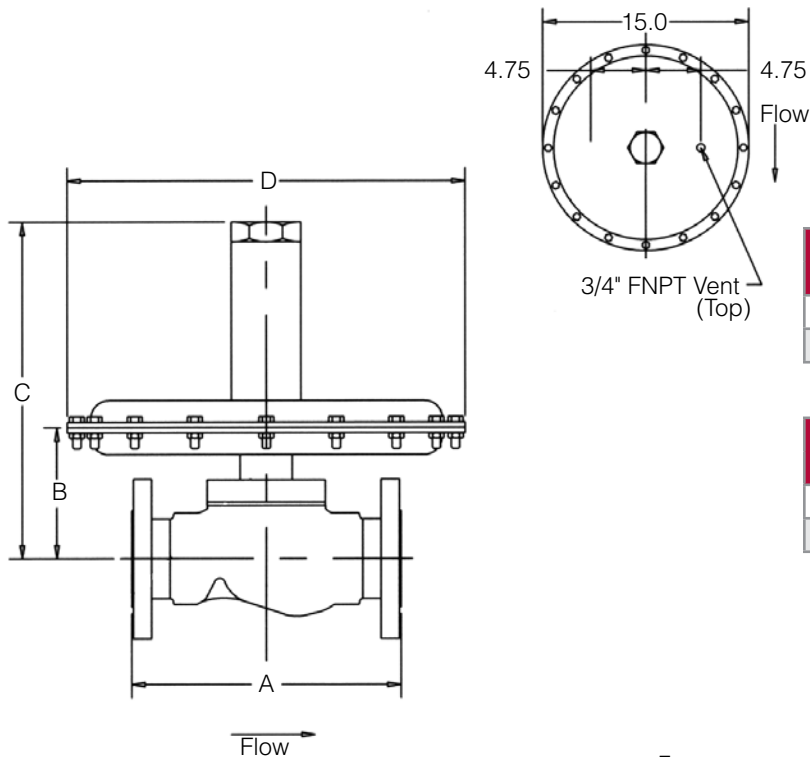

Valve Size	Dimensions (inches)			
	A	B	C	D
1-1/2"	8.75	4.93	12.32	15.0
2"	10.00	4.93	12.32	15.0

Valve Size	Dimensions (metric)			
	A	B	C	D
DN40	222,3	125,2	313	381
DN50	254.0	125,2	313	381

MARK 508 GAS BACK PRESSURE REGULATOR

1-1/2" MARK 508 SERIES FLOW CAPACITIES

		Flow Rate @ Pressure Over Set Point (SCFH)						
Range	Set Point	2.0" WC (5,0 mbar)	4" WC (10,0 mbar)	8" WC (19,9 mbar)	0.50 psi (0,7 bar)	1 psi (1,0 bar)	2 psi (1,4 bar)	3 psi (1,7 bar)
2.0 - 5.0 WC	3.0" WC	1496	2134	2938	4034	6291	9380	11980
5,0 - 12,5 mbar	7,5 mbar	42	60	83	114	178	266	339
4.0 - 8.0" WC	5.0" WC	1886	2537	3397	4484	6297	9481	12202
	7.0" WC	1971	2828	3642	4612	6893	9565	12195
10,0 - 20,0 mbar	12,5 mbar	53	72	96	127	178	268	346
	17,4 mbar	56	80	103	131	195	271	345
8.0 - 28" WC	10.0" WC	1786	3239	4390	5115	7115	10060	12646
	25.0" WC	1411	3683	6098	6989	8707	11444	13737
20,0 - 70,0 mbar	24,9 mbar	51	92	124	145	201	285	358
	62,3 mbar	40	104	173	198	247	324	389
10.0 - 17.0" WC	12.0" WC	2014	3493	4688	5648	7199	10270	12889
	15.0" WC	2264	3977	5262	5907	7598	10445	13047
24,9 - 42,4 mbar	28,9 mbar	57	99	133	160	204	291	365
	37,4 mbar	64	113	149	167	215	296	369
14.0 - 28.0" WC	15.0" WC	1979	3451	5056	5949	7555	10611	13169
	25.0" WC	1858	3716	5916	7107	8662	11535	13807
34,9 - 70,0 mbar	37,4 mbar	56	98	143	168	214	300	373
	62,3 mbar	53	105	168	201	245	327	391
0.75 - 1 psi	0.75 psi		3498	5525	6479	8316	11153	13788
	1 psi		2951	5824	7370	9011	11736	15160
51,7 - 69,0 mbar	51,7 mbar		99	156	183	235	316	390
	68,8 mbar		84	165	209	255	332	429
1 - 2 psi	1.5 psi			5310	8443	10312	12812	16120
	2.0 psi			5568	8960	11444	13941	17024
69,0 - 137,9 mbar	0,10 bar			150	239	292	363	456
	0,14 bar			158	254	324	395	482
1.5 - 3 psi	2.0 psi				8295	11568	13835	17046
	3.0 psi				8463	13218	16575	18756
0.10 - 0,21 bar	0,14 bar				235	328	392	483
	0,21 bar				240	374	469	531
3 - 5 psi	3.5 psi				6208	12356	16925	19025
	5.0 psi				5655	11412	18093	20658
0,21 - 0,34 mbar	0,24 bar				176	350	479	539
	0,34 bar				160	323	512	585

Nitrogen at 0.97 s.g. in scfh and Nm<sup>3</sup>/hr  
 Operation in shaded areas not recommended

MARK 508 GAS BACK PRESSURE REGULATOR

**2" MARK 508 SERIES FLOW CAPACITIES**

		Flow Rate @ Pressure Over Set Point (SCFH)						
Range	Set Point	2.0" WC (5,0 mbar)	4" WC (10,0 mbar)	8" WC (19,9 mbar)	0.50 psi (0,7 bar)	1 psi (1,0 bar)	2 psi (1,4 bar)	3 psi (1,7 bar)
2.0 - 5.0 WC	3.0" WC	1663	2371	3264	4482	6990	10422	13311
5,0 - 12,5 mbar	7,5 mbar	47	67	92	127	198	295	377
4.0 - 8.0" WC	5.0" WC	2095	2819	3775	4982	6997	10535	13558
	7.0" WC	2190	3142	4047	5125	7659	10628	13550
10,0 - 20,0 mbar	12,5 mbar	59	80	107	141	198	298	384
	17,4 mbar	62	89	115	145	217	301	384
8.0 - 28" WC	10.0" WC	1984	3599	4878	5684	7905	11178	14052
	25.0" WC	1568	4092	6776	7765	9675	12716	15263
20,0 - 70,0 mbar	24,9 mbar	56	102	138	161	224	317	398
	62,3 mbar	44	116	192	220	274	360	432
10.0 - 17.0" WC	12.0" WC	2238	3882	5209	6276	7999	11411	14321
	15.0" WC	2515	4419	5847	6563	8442	11606	14497
24,9 - 42,4 mbar	28,9 mbar	63	110	148	178	227	323	406
	37,4 mbar	71	125	166	186	239	329	411
14.0 - 28.0" WC	15.0" WC	2199	3834	5617	6610	8395	11790	14632
	25.0" WC	2064	4128	6573	7896	9625	12817	15342
34,9 - 70,0 mbar	37,4 mbar	62	109	159	187	238	334	414
	62,3 mbar	58	117	186	224	273	363	434
0.75 - 1 psi	0.75 psi		3887	6139	7199	9240	12392	15320
	1 psi		3279	6471	8189	10012	13040	16845
51,7 - 69,0 mbar	51,7 mbar		110	174	204	262	351	434
	68,8 mbar		93	183	232	284	369	477
1 - 2 psi	1.5 psi		5900	9381	11457	14235	17911	
	2.0 psi		6186	9956	12716	15490	18916	
69,0 - 137,9 mbar	0,10 bar		167	266	324	403	507	
	0,14 bar		175	282	360	439	536	
1.5 - 3 psi	2.0 psi		9216	12853	15372	18940		
	3.0 psi		9403	14687	18416	20840		
0.10 - 0,21 bar	0,14 bar		261	364	435	536		
	0,21 bar		266	416	521	590		
3 - 5 psi	3.5 psi		6898	13728	18806	21138		
	5.0 psi		6283	12680	20103	22953		
0,21 - 0,34 mbar	0,24 bar		195	389	533	599		
	0,34 bar		178	359	569	650		

Nitrogen at 0.97 s.g. in scfh and Nm<sup>3</sup>/hr  
 Operation in shaded areas not recommended

**ORDERING SCHEMATIC (1-1/2" & 2")**

Model No	Size	Body Mat'l	1	2	3	4	5	6	7	8	9	10	11	12

Model	
508	Standard

Size	
150	1-1/2" (DN40)
200	2" (DN50)

Body Material	
BR	Bronze
CS	Carbon Steel (WCB)
S6	Stainless Steel (CF8M)

End Connections	
PT	NPT
F5	150#FE
ZZ	Non-Standard

Seat & Diaphragm	
BN	Buna-N
VN	Viton
EN	EPDM

5 & 6 Range		
	W.C.	mbar
07	2 - 5" W.C.	5,0 - 12,5 mbar
08	4 - 8" W.C.	10,0 - 19,9 mbar
09	8 - 28" W.C.	19,9 - 70,0 mbar
10	10 - 17" W.C.	24,9 - 42,3 mbar
11	14 - 28" W.C.	34,9 - 70,0 mbar
12	0.75 - 1 psi	51,7 - 69,0 mbar
13	1 - 2 psi	69,0 - 137,9 mbar
14	1.5 - 3 psi	0,10 - 0,21 bar
15	3 - 5 psi	0,21 - 0,34 bar
ZZ	Non-Standard	

7 & 8 Actuator	
SD	Standard
ZZ	Non-Standard

9 & 10 Bushing	
TF	Teflon
CG	Carbon Graphite
ZZ	Non-Standard

11 & 12 PED Compliance	
00	Not Required
FF	CE Category 1
ZZ	Non-Standard

