

Mark 95 Series

Sanitary Back Pressure Regulators

The Mark 95 is available with a hard or soft seat and a variety of diaphragm and o-ring materials, making the valve well-suited for virtually any sterile back pressure application.

The Mark95 operates by sensing the inlet pressure, or back pressure, beneath the diaphragm, as flow enters from inlet port on the side. As the back pressure exceeds the setpoint, the diaphragm force compresses the range spring permitting the stem to move from the seat toward the open position. As the flow increases, the back pressure is relieved and the spring and diaphragm relax, allowing the stem to return to the normally closed position. If a different set point is desired, a simple turn of the adjusting screw will increase or decrease the setting to any set point within the range covered by the regulator's spring.

FEATURES

- Soft seat capability for ANSI Class VI shutoff
- No guiding surfaces in the fluid – prevents particulate generation
- 100% 316L barstock body and trim
- Self-draining
- No threads to disassemble for cleaning
- Clean-in-Place, Steam-in-Place – dome features spring arrangement to allow CIP/SIP
- Remote setpoint capability
- Lifetime warranty on Jorlon diaphragm

DOCUMENTATION

The following documentation is shipped with each order:

- Steriflow Unicert
 - Traceable Material Heat Number for body and ferrels
 - Certificate of Compliance to FDA and USP Class VI

Certificate of Surface Finish

- Final Test Reports and Certificate of Origin available upon request at time of order



AVAILABLE FINISHES (MK95/MK95FT)

Body

- *Standard:* 20 Ra mechanical finish and electropolish on inside wetted surfaces; machine finish and electropolish on exterior. Re: ASME BPE 2005, SFV5
- *Optional:* 20 Ra (SFV5) mechanical finish and electropolish on external surfaces; 8 Ra finish on internal or external finishes and electropolish Re: Better than SFV4

Spring Housing and Handle

- *Standard:* machine finished 316SST, electropolished
- *Optional:* 20 Ra mechanical finish and electropolish on external surfaces. Re: ASME BPE 2005, SFV5; 8 Ra finish on external surfaces on all sizes and electropolish. Re: Better than SFV4

Adjusting Screw

- *Standard:* 32Ra (Note: adjusting screw is a threaded part)

APPLICATIONS

The MK95 is suitable for a variety of process and clean utility applications in the biopharmaceutical, semi-conductor, and food & beverage industries including: continuous circuit WFI pump deadhead diversion, bioreactor agitator seal pressure maintenance, large volume fill back pressure release, and zero dead leg pressure relief.

SPECIFICATIONS – O-RING DIAPHRAGM

Sizes: 1/2" (DN15), 3/4" (DN20), 1" (DN25), 1-1/2" (DN40), 2" (DN50), 3" (DN80)

End Connections

- Quick disconnect fittings (*to match Tri-Clamp® fitting*)
- DIN/ISO sanitary connections

Body & Trim Materials: 316L Stainless Steel (ASTM A47, S31603)

Seat Materials

- Standard hard seat – integral 316L SST seat
- Optional soft seat (for Cv 1.5, 1" size and above) – Jorlon for steam and hot gas service to 338°F (170°C) or TFE for cold gas and liquid service to 150°F (65°C) – all FDA, USP Class VI.

Note: consult factory for 3/4" soft seat materials.

Spring Housing Materials

- CF8M cast SST (1/2" – 1-1/2")
- Fabricated 316L SST (2" – 3")

Diaphragm Materials

- 316L SST
- EPDM/Nylon (to 275°F, 135°C)
- Teflon-coated Viton (to 400°F, 204°C) in 1/2" - 1" sizes only
- Jorlon (to 450°F, 232°C) – FDA, USP Class VI

O-Ring Materials

- EPDM (to 275°F, 135°C) - FDA, *USP Class VI
- Buna-N (to 225°F, 107°C) - FDA, *USP Class VI
- Viton (to 400°F, 232°C) - FDA, *USP Class VI
- Silicone (to 450°F, 232°C) - FDA, *USP Class VI
- Teflon-Encapsulated Viton (to 400°F, 204°C) - FDA, *USP Class VI
- Teflon-Encapsulated Silicone (to 400°F, 204°C)

**USP Class VI materials available upon request*

Shutoff: ANSI Class III hard seat or Class VI soft seat

Body Pressure Temperature Rating: (dependent upon construction)

Set Point Spring Ranges

Valve Size	Set Point Ranges, PSI (bar)
1/2", 3/4" & 1"	2-8* (0,1-0,5), 5-30 (0,3-2,1), 15-50 (1,0-3,4), or 35-90 (2,4-6,2)
1-1/2"	3-25* (0,2-1,7), 10-25 (0,7-1,7), 15-40 (1,0-2,8) or 35-85 (2,4-5,9)
2"	15-25* (0,3-1,7), 10-25 (0,7-1,7) or 15-60 (1,0-4,1)
3"	15-25 (1,0-1,7) or 15-60 (1,0-4,1)

* Range available with elastomer diaphragm only. Maximum pressure drop 40 psi.

Cv (Kv) Ratings:

Valve Size	Metal Diaphragms Cvs (Kvs)	Elastomer Diaphragm Cvs (Kvs)
1/2", 3/4"	0.5 (04,), 1.5 (1,3)	0.5 (04,), 1.5 (1,3)
1"	1.5 (1,3), 3.0 (2,6) or 4.5 (3,9)	1.5 (1,3), 3.0 (2,6) or 5.5 (4,7)
1-1/2"	4.5 (3,9) or 10.0 (8,6)	4.5 (3,9) or 10.0 (8,6)
2"	10.0 (8,6) or 19.0 (16,3)	10.0 (8,6) or 19.0 (16,3)
3"	10.0 (8,6) or 23.0 (19,8)	10.0 (8,6) or 23.0 (19,8)

Maximum Allowable Pressure Differential: 200 psi (2-8 spring range has a max of 40 psi)

Valve Size	PSIG @ 100°F	PSIG @ 450°F
1/2", 3/4" & 1"	350 (24,1 bar)	250 (17,2 bar)
1-1/2", 2" & 3"	200 (13,8 bar)	200 (13,8 bar)

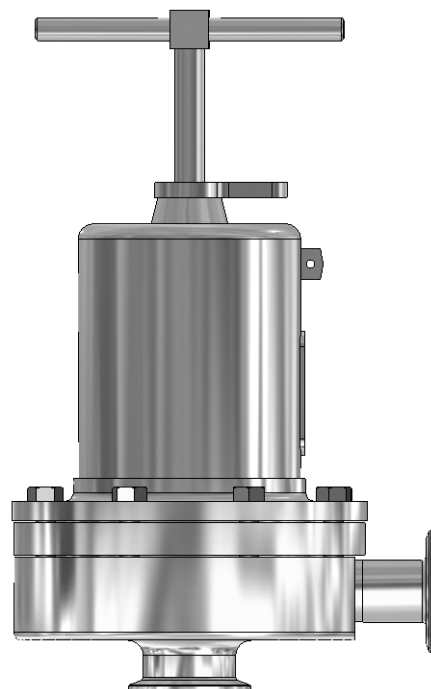

FEATURES & BENEFITS

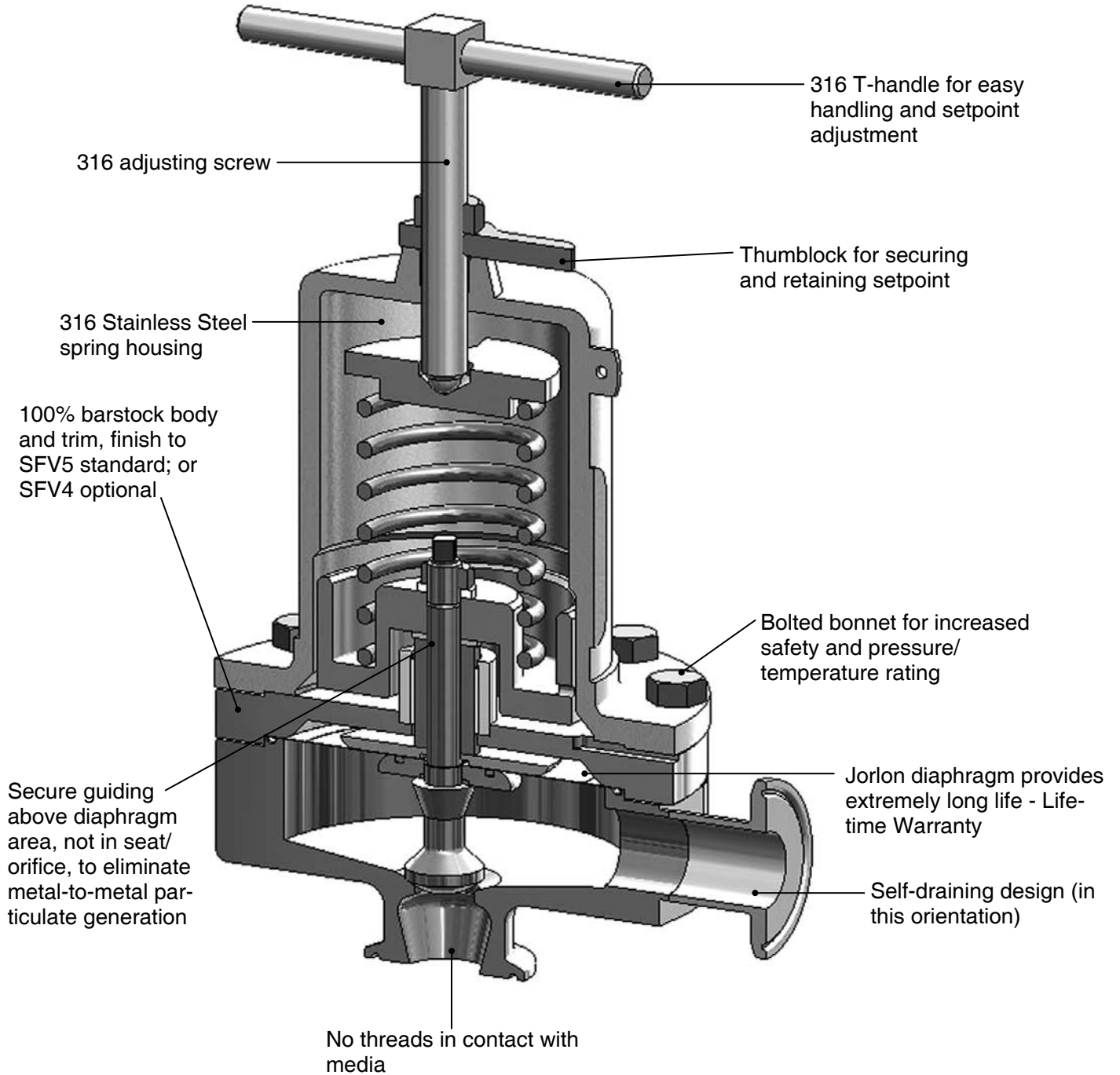

DIMENSIONS

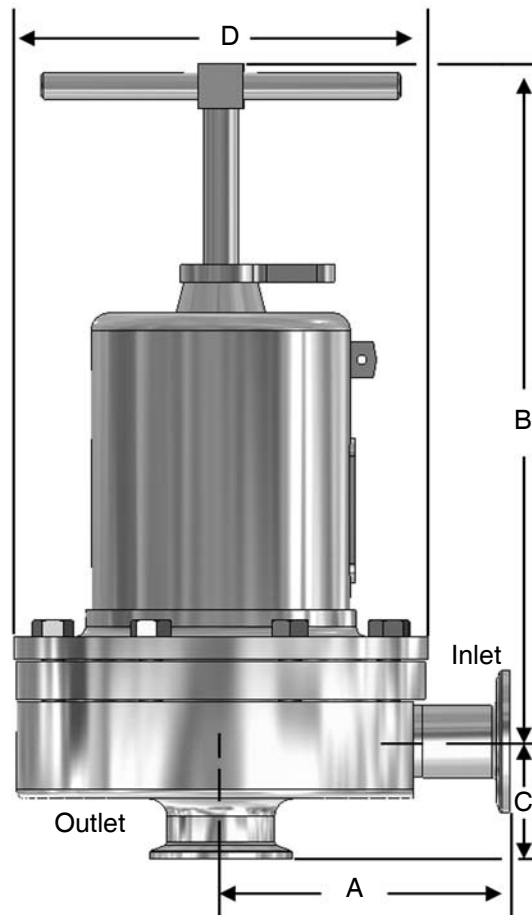

Valve Size	Dimensions (inches)				Weight Lbs
	A	B	C	D	
1/2"	3.29	8.50	1.50	5.70	18
3/4"	3.29	8.50	1.50	5.70	18
1"	4.00	8.50	1.64	5.70	20
1-1/2"	4.24	10.50	2.53	7.25	40
2"	5.34	17.50	2.96	9.50	90
3"	5.34	18.00	3.46	9.50	98

Valve Size	Dimensions (mm)				Weight Kgs
	A	B	C	D	
DN15	84	216	38	145	8,1
DN20	84	216	38	145	8,1
DN25	102	216	42	145	9,1
DN40	108	267	64	184	18
DN50	136	445	75	241	41
DN80	136	457	88	241	44,4

SAMPLE SPECIFICATION

Stainless steel sanitary back pressure regulator body and wetted components shall be made from 316L, ASTM A479, S31603 barstock material. Regulator shall be activated by FDA approved, USP Class VI certified Jorlon diaphragm with lifetime guarantee. All guiding of valve stem/plug shall be outside of the wetted, process areas, above diaphragm. Regulator shall be free of threads within wetted, process areas of valve internal and shall be self draining when installed with outlet vertical and below valve assembly.

Mark 95FT Series

Sanitary "Flow Through" Back Pressure Regulators

Starting with the features and benefits associated with the superior design of the Mark 95, Steriflow Valve has added a flow-through option that creates more application potential. The MK95FT can eliminate a portion of the by-pass line components by allowing the back pressure regulating valve to be installed in the primary line – not in the separated by-pass line.

The Mark 95FT is often found in liquid services such as WFI loops, CIP lines and filling lines. The valve is normally closed, allowing flow to pass straight through to downstream users. When demand downstream is reduced and pressure builds and reaches the setpoint, the Mark 95FT will open to relieve and maintain constant pressure. This design allows for elimination of pipe "T's" and elbows, reduction of weld joints, simplified by-pass piping and easier, quicker installation. Due to the unobstructed flow path through the valve, very little to no pressure loss through the valve can be expected. This is a key reason the MK95FT can be installed directly into the primary process piping.

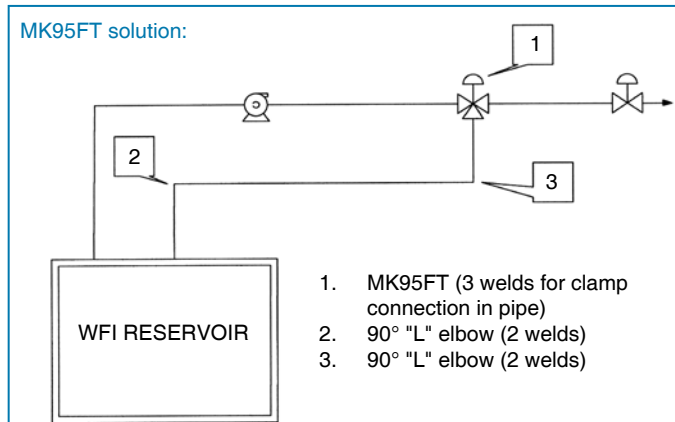
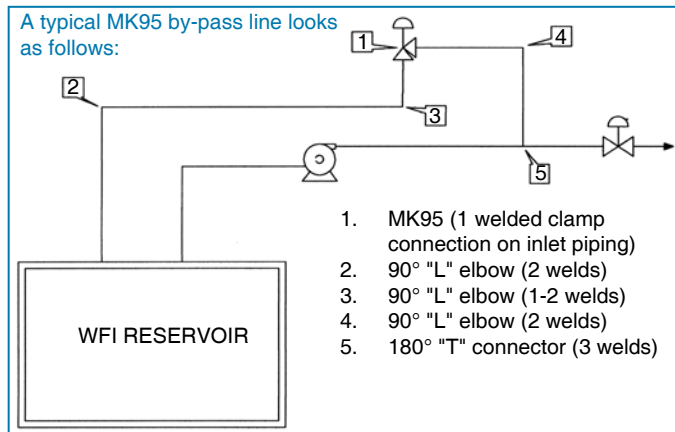
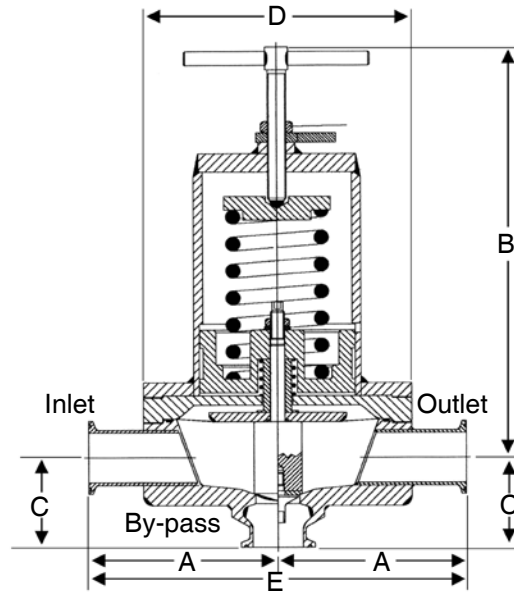

Valve Size	Dimensions (inches)					Weight Lbs
	A	B	C	D	E	
3/4"	3.29	8.50	1.50	5.70	6.58	19
1"	4.00	8.50	1.64	5.70	8.00	21
1-1/2"	4.24	10.5	2.53	7.25	8.48	41
2"	5.34	17.5	2.96	9.50	10.7	91
3"	5.34	18.0	3.46	9.50	10.7	99

Valve Size	Dimensions (mm)					Weight Kgs
	A	B	C	D	E	
DN20	84	216	38	145	173	8,6
DN25	102	216	42	145	203	9,5
DN40	108	267	64	184	214	19
DN50	136	445	75	241	271	41
DN80	136	457	88	241	271	45

ORDERING SCHEMATIC

					1 & 2	3 & 4	5 & 6	7 & 8	9 & 10	11 & 12	13 & 14
--	--	--	--	--	-------	-------	-------	-------	--------	---------	---------

Model	
95	Standard
95FT	Flow-Through

Size	
050	1/2" (DN15)
075	3/4" (DN20)
100	1" (DN25)
150	1-1/2" (DN40)
200	2" (DN50)
300	3" (DN80)

Body Material	
6L	316L

1 & 2		Body	
		Finish	Cvs (Kvs)
A	20Ra Interior/63rms Exterior (Std)	A	0.5 & 1.5 (0,5 & 1,3)
B	20Ra Interior/20Ra Exterior	G	3.0 (2,6)
C	8Ra Interior/63rms Exterior	H	4.5 (3,9)
D	20Ra Interior/8Ra Exterior	K	5.5 (4,7)
E	8Ra Interior/8Ra Exterior	M	10.0 (8,6)
F	8Ra Interior/20Ra Exterior	N	19.0 (16,3)
		P	23.0 (19,8)

3		Trim Finish	
A	20Ra (Standard)		
B	8Ra		

4		Trim – Cv (Kv) & Seat			
5	0.5 (0,4) Hard Seat	N	5.5 (4,7) Jorlon Seat		
A	1.5 (1,3) Hard Seat	P	10 (8,6) Hard Seat		
E	3.0 (2,6) Hard Seat	Q	10 (8,6) Teflon Seat		
F	3.0 (2,6) Teflon Seat	R	10 (8,6) Jorlon Seat		
G	3.0 (2,6) Jorlon Seat	S	19 (16,3) Hard Seat		
H	4.5 (3,9) Hard Seat	T	19 (16,3) Teflon Seat		
J	4.5 (3,9) Teflon Seat	U	19 (16,3) Jorlon Seat		
K	4.5 (3,9) Jorlon Seat	V	23 (19,8) Hard Seat		
L	5.5 (4,7) Hard Seat	W	23 (19,8) Teflon Seat		
M	5.5 (4,7) Teflon Seat	X	23 (19,8) Jorlon Seat		

5 & 6		O-Ring/Diaphragm	
		Cv 0.5 thru 3.0	
BS	Buna/SST Dia.		
EL	EPDM/EPDM Dia.		
ES	EPDM/SST Dia.		
SS	Silicone/SST Dia.		
TL	Teflon Encap. Silicone/SST Dia.		
TF	Teflon Encap. Viton/TFE-Vit Dia.		
TG	Teflon Encap. Viton/Jorlon Dia.		
TE	Teflon Encap. Viton/SST Dia.		
VS	Viton/SST Dia.		
ZZ	Non-standard		

5 & 6		O-Ring/Diaphragm	
		Cv > 3.0	
BU	Buna/SST Dia.		
EE	EPDM/EPDM Dia.		
EP	EPDM/SST Dia.		
SL	Silicone/SST Dia.		
TS	Teflon Encap. Silicone/SST Dia.		
TT	Teflon Encap. Viton/TFE-Vit Dia.		
TY	Teflon Encap. Viton/Jorlon Dia.		
TV	Teflon Encap. Viton/SST Dia.		
VT	Viton/SST Dia.		
ZZ	Non-standard		

7		Adjusting Screw Finish (Except Threads)	
A	Electro-polished (Standard)		
B	20Ra (SFV5)		
C	8Ra		

8		Range PSI (Bar)	
A	2 - 8 (0,1 - 0,6)/Elas. Diaphragm		
B	3 - 25 (0,3 - 1,7)/Elas. Diaphragm		
D	5 - 30 (0,3 - 2,1)		
E	10 - 25 (0,7 - 1,7)		
F	5 - 25 (0,3 - 1,7)/Elas. Diaphragm		
P	15 - 25 (1,0 - 1,7)		
G	15 - 40 (1,0 - 2,8)		
H	15 - 50 (1,0 - 3,4)		
J	15 - 60 (1,0 - 4,1)		
K	35 - 85 (2,4 - 5,9)		
L	35 - 90 (2,4 - 6,2)		
Q	50 - 105 (3,4 - 7,2)		

9 & 10		Diaphragm	
6L	SST (all exterior)		
EP	EPDM (all exterior)		
JL	Jorlon (all exterior)		
TV	TFE-Viton (standard exterior)		
BV	TFE-Viton (20Ra (SFV5) exterior)		
DV	TFE-Viton (8Ra exterior)		

11 & 12		Actuator Finish/Type	
AA	Standard		
BA	20Ra (SFV5) exterior		
CA	8Ra exterior		
DA	Electro-polished for 2" & 3"		
EA	Anodized Aluminum (1-1/2" - 3")		

13 & 14		PED Compliance	
00	Not Required		
FF	CE Category 1		



Steriflow, a division of Jordan Valve

3170 Wasson Road • Cincinnati, OH 45209
 513.533.5600 • 800.543.7311 • 513.871.0105 (f)
 steriflow@richardsind.com • www.steriflowvalve.com

Steriflow Valve reserves the right to make revisions to its product, specifications, literature and related information without notice. Please visit our website at www.steriflowvalve.com for the latest information on our products.