

THREADED & FSW ENDS						
SIZE DN	MAT'L	DIMENSIONS, mm				Wt. Kg.
		A	B	C	D	
15 & 20	DI/BRZ	92	495.5	55	180.1	10
	CS/SS	93	495.5	55	180.1	10.4
25	DI/BRZ	105	502.6	67	180.1	10.9
	CS/SS	105	502.6	67	180.1	11.3
32	DI/BRZ	105	502.6	67	180.1	10.9
40	DI/BRZ	114	508.2	67	180.1	11.3
	CS/SS	118	508.2	70	180.1	11.8
50	DI/BRZ	114	511.3	67	180.1	12.2
	CS/SS	140	511.3	76	180.1	13.6

FLANGED END						
SIZE DN	FLANGE PN	DIMENSIONS, mm				Wt. Kg.
		A ₁	B	C	D	
15	10/16	130	495.5	55	180.1	10.9
	25/40	130	495.5	55	180.1	12.2
20	10/16	150	495.5	55	180.1	11.8
	25/40	150	495.5	55	180.1	13.2
25	10/16	160	502.6	67	180.1	13.2
	25/40	160	502.6	67	180.1	14.1
32	10/16	180	502.6	67	180.1	12.7
	25/40	180	502.6	67	180.1	14.5
40	10/16	200	508.2	70	180.1	14.1
	25/40	200	508.2	70	180.1	17.2
50	10/16	230	511.3	76	180.1	16.8
	25/40	230	511.3	76	180.1	20.0

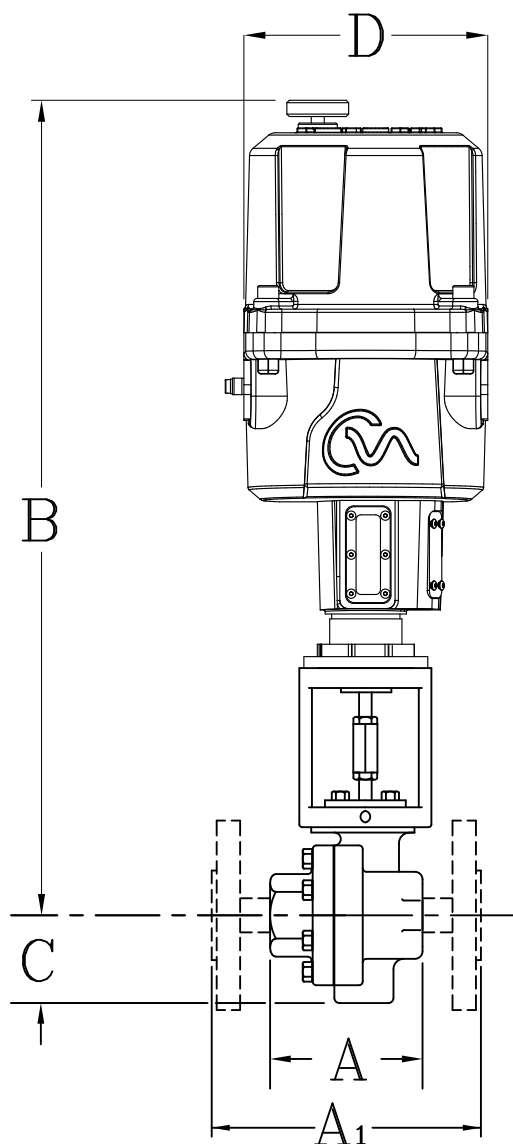

* AN ADDITIONAL 5 3/4" IS NEEDED TO REMOVE MOTOR COVER FOR ELECTRICAL CONNECTIONS.

* CML 100 & CML 250 HAVE SAME MOUNTING DIMENSIONS

TOLERANCES

BWE, FE, TRI-C & TUBE END F-F DIM ARE ±1.57mm
ALL OTHER DIMENSIONS: ±12.7mm

SPECIFICATION DATA	
CUSTOMER	_____
ORDER No.	_____ SERIAL No. _____
TAG No.	_____
VALVE TYPE	_____ QTY. _____
BODY	_____
END CONN.	_____
INLET PRESS.	_____ MAX. ΔP _____
CONTROL RANGE	_____
VALVE ACTION: RISE IN SIGNAL TO	<input type="checkbox"/> OPEN
	<input type="checkbox"/> CLOSE
VALVE SEAT	_____ Cv _____
MISC.	_____
CERTIFIED	_____ DATE _____

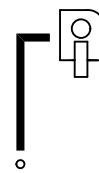
 **RICHARDS INDUSTRIES**
CINCINNATI, OHIO
U.S.A.
VALVE GROUP

F.N.: MK37-CML-M

15-50 mm MK37 CONTROL VALVE-METRIC
W/CML 100/250 MOTOR FOR Ma & VOLT CONTROL

DRAWN BY	DATE
UAS	3/31/16
CHECKED BY	DATE

MK37-CML
METRIC