



3170 Wasson Road • Cincinnati, OH 45209 USA
 Phone 513-533-5600 • Fax 513-871-0105
 info@richardsind.com • www.jordanvalve.com

I & M Mark 75 (4" – 8")

Installation & Maintenance Instructions for Mark 75 Wafer Control Valve

Warning: Jordan Valve Control Valves must only be used, installed and repaired in accordance with these Installation & Maintenance Instructions. Observe all applicable public and company codes and regulations. In the event of leakage or other malfunction, call a qualified service person; continued operation may cause system failure or a general hazard. Before servicing any valve, disconnect, shut off, or bypass all pressurized fluid. Before disassembling a valve, be sure to release all spring tension.

Please read these instructions carefully!

Your Jordan Valve product will provide you with long, trouble-free service if it is correctly installed and maintained. Spending a few minutes now reading these instructions can save hours of trouble and downtime later. When making repairs, use only genuine Jordan Valve parts, available for immediate shipment from the factory.

Ideal Installation

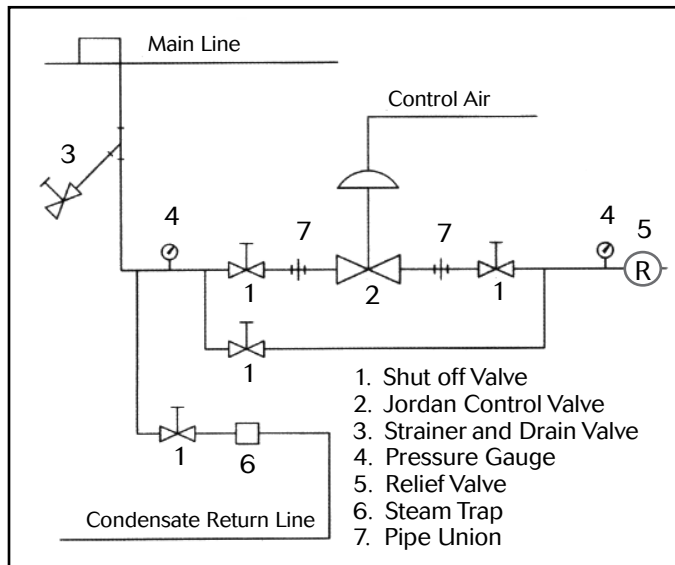

- To protect the valve from grit, scale, thread chips and other foreign matter, ALL pipelines and piping components should be blown out and thoroughly cleaned before the installation process begins.
- Shutoff valves, pressure gauges and by-pass piping should be installed as indicated in the diagram above to provide easier adjustment, operation, and testing.
- A line strainer should be installed on the inlet side of the valve to protect it from grit, scale and other foreign matter. A 0.033 perforated screen is usually suitable for this purpose. Line strainers are available from Jordan Valve.
- For best control, 3' 0" straight sections of pipe

- should be installed on either side of the valve.
- The disc in the valve body must be positioned in the upstream portion of the flow, and the set-screws should be on the downstream side of the valve. Ideally for steam applications, the valve should be installed in the highest horizontal line of piping to provide drainage for inlet and outlet piping, to prevent water hammer, and to obtain faster response.
- If possible, install a relief valve downstream from the valve. Set at 15 psi above the control point of the valve.
- In hot vapor lines, upstream and downstream piping near the valve should be insulated to minimize condensation.
- In gas service, expand the outlet piping at least one pipe size, if the control pressure (downstream) is 25 percent of the inlet pressure or less. A standard tapered expander connected to the outlet of the valve is recommended.
- Where surges are severe, a piping accumulator is recommended.
- On steam control applications, install a steam trap with sufficient capacity to drain the coil or condenser. Be sure to have a good fall to the trap, and no backpressure. Best control is maintained if the coil or condenser is kept dry.
- Tighten pipe flange bolts just enough to effect a good seal.

Start-Up Procedure

- Be sure that the action of the control valve and of the controller are such that you achieve the desired results.

Increase in pressure or temperature must:	And the action of the valve is:	Then the action of the controller must be:
Close Valve	Air to Close (Direct)	Direct
Close Valve	Air to Open (Reverse)	Reverse
Close Valve	Air to Close (Direct)	Reverse
Close Valve	Air to Open (Reverse)	Direct

PROTECT VALVES WITH LINE STRAINERS

2. The control valve has been pre-set by Jordan Valve, however, finer adjustment may be required to compensate for the system conditions of your application.
3. With inlet, outlet and bypass shutoff valves closed, and no pressure in the downstream line, gradually open the inlet valve enough to start flow through the control valve. Increase the flow gradually by slowly opening the inlet shutoff valve. Do not fully open the inlet valve until you are sure that the controller and control valve have control of the system. Usually, the handwheel on the inlet valve will turn freely when this point is reached.
4. To shut off the line fluid, close the inlet shutoff valve first, and then close the outlet shutoff valve.
5. Remove the pipe plug (62) and loosen the set screw(61). Replace the pipe plug (62).
6. It may be necessary to re-torque the pipe flange bolts.

Maintenance

Caution: Make certain that there is no pressure in the valve before loosening any fittings or joints. The following steps are recommended:

1. Close the inlet shutoff valve.
2. Allow pressure to bleed off through the downstream piping. Do not attempt to reverse the flow through the valve by bleeding pressure from the upstream side of the valve.
3. When the pressure gauges indicate that all pressure has been removed from the system, close the outlet shutoff valve and the valve may be serviced.

Note: refer to the drawing at the end of this document for description and proper orientation of parts.

Valve Seats

A. Disassembly

The sliding Gate Seats of Jordan Valves are lapped to light band flatness. Maintaining such tolerances is of paramount importance for your assurance of excellent control and tight shutoff. DO NOT use metallic objects in removing the seats. Care in handling is imperative.

1. Remove the pipe plug (62) (**8" only**), and tighten the set screw (61). Keep the pipe plug in a secure place. Follow instructions under the Maintenance section to remove valve from line.
2. Disassemble the valve only as far as necessary to do the required work.
3. When replacing seats it is recommended by Jordan Valve that the packing be replaced if the valve is older than one year. Follow the instructions under Packing Replacement.
4. Remove the Set screws (61), and remove the Plate (47) and Disc (48). Place the plate on the bench with the lapped surface up.
5. Clean all parts of the Body (46) with a good quality

solvent. Remove Shoulder Screws (43) and Wave Springs (51), the Disc (48) and Plate (47) can then be cleaned. Place a piece of 4/0 polishing cloth or jeweler's cloth on a smooth flat surface such as a surface plate and polish the Disc, and Plate lapped surfaces using a figure "8" motion. If the parts are scarred, do not attempt to re-lap them, but return them to the factory for repair or replacement.

B. 6" Reassembly

1. Locate the markings "TOP REV" and "TOP DIR" on the back of the plate (47). If the valve action is "air to open", place the Plate on a clean, flat work surface with the words "TOP REV" away from you and the lapped side up and words down. If the valve action is "air to close", place the Plate on a clean, flat work surface with the words "TOP DIR" away from you and the lapped side up.
2. If the valve action is "air to open", place the Disc (48) on the Plate with the words "TOP REVERSE" away from you. If the valve action is "air to close", the words "TOP DIRECT" should be away from you. Move the Disc (48) until the slots are in perfect alignment with those of the plate (47).
3. Place the Wave Springs (51) on the Shoulder Screws (43). Insert them through the vertical slots in the Disc (48), and tighten until a mechanical stop is felt. DO NOT OVERTIGHTEN. The Disc (48) should move freely up and down, but not side to side.
4. Hold the Plate / Disc Assembly (47 & 48) together and insert it into the large end of the Body (46) with the slots perpendicular to the stem (42), taking care that the "T" slot in the Disc (48) engages the head of the valve stem. *The word "TOP REV" should be towards the actuator for air to open. The word "TOP DIR" should be towards the actuator for air to close.*
5. Replace the Set Screws (61).
6. Follow instructions under Installation & Start Up Procedure when placing valve back in service.

B. 8" Reassembly

7. Place the plate (47) on a clean, flat work surface with the lapped side up. The small single locator hole should be towards you.
8. If the valve action is "air to open", place the Disc (48) on the Plate with the words "TOP REVERSE" away from you. If the valve action is "air to close", the words "TOP DIRECT" should be away from you. Move the Disc (48) until the slots are in perfect alignment with those of the plate (47).
9. Place the Wave Springs (51) on to the Shoulder Screws (43). Insert them though the vertical slots in the Disc (48), and tighten until a mechanical stop is felt. DO NOT OVERTIGHTEN. The Disc (48) should move freely up and down, but not side to side.
10. Hold the Plate / Disc assembly (47 & 48) together and insert it into the large end of the Body (46) with the slots perpendicular to the stem (42), taking

care that the "T" slot in the Disc (48) engages the head of the valve stem. *The word "TOP" should be towards the actuator.*

11. Replace the Set Screw (61) and the Pipe Plug (62).
12. Follow instructions under Installation & Start Up Procedure when placing valve back in service.

Stem & Packing Replacement

1. Remove the Plate (47) and Disc (48), following the procedure outlined under the Valve Seats section.
2. Loosen the Stem Connector Nut (18) and Bolt (17) and remove Connector Halves (13).
3. Back out the Yoke SST Screws (12) and allow the Body (46) to separate from the Yoke (10).
4. Remove the Packing Flange Nuts (9) and the Packing Flange (7).
5. When pulling the Stem (42) completely out of the Body, you will remove most of the Packing Assembly (2,5,6) also. The remaining parts of the Packing Assembly can "fished" out with a small screwdriver. *(Be careful not to damage the packing bore.)*
6. Clean the packing bore in the Body with solvent and blow dry.
7. Clean the Stem (42) with solvent if it is to be reused.
8. Replace the Packing Spring (1) and Packing Retainer (2) in the packing bore.
9. Reassemble the new Packing (5) on the stem (42) with the open part of the "V" downward (^). *There will be a flat on the top and bottom. Place the Packing Follower (6) on top of the Packing (5). (Coat each piece of the packing set with a suitable lubricant.)*
10. Gently push the Packing (5) into the packing bore and place the Packing Flange (7) on the stem.
11. Put the Packing Flange Nuts (9) on the Packing Studs (8) and partially tighten. *At this point it is recommended that you gently move the stem up and down three or four times to align the assembly.*
12. Tighten the Packing Flange nuts (9) until the Packing Follower (6) bottoms out on the top of the body.
13. Reassemble Yoke (10) to the valve Body (46) with the four Yoke Screws (12). Reassemble the Seats by inserting in the body as outlined in Valve Assembly Section.

Actuator

CAUTION: DO NOT apply more than 45 psi to the actuator.

The valve need not be removed from the line; however before performing any maintenance on the actuator:

- Since there will be no control of the valve available it is recommended that the valve be isolated from the service.
- Shut off the control air supply and remove the control line from the actuator.

- Remove the stem connector assembly Upper Stem Adapter (19) to the Valve Stem (42) using the Stem Connector Halves (13), the Stem Connector Bolt (17), Lockwasher (16), Nut (18), and Travel Pointer (14).

A. Actuator Disassembly

1. Remove the actuator assembly from the valve by removing the four Adaptor Plate Bolts (27), and lift the actuator assembly off the Yoke (10).
2. Place the actuator assembly on its top, (side with the control line connection). Release the spring compression, by threading the Actuator Stem (24) out of the actuator, by turning it counterclockwise.
3. Remove the Actuator Bolts and Nuts (37) and separate the two halves, (Upper Case [40] and Lower Case [26]), of the actuator assembly. Remove the six Range Springs (30) from the diaphragm plate.
4. Lift out the diaphragm assembly. Loosen and remove the two Actuator Jam Nuts (36) from the Actuator Bolt (34). Remove the Diaphragm Plate (29 & 31), Diaphragm (32), Diaphragm Stop (33), and the Fastener Seal (35) from the Actuator Bolt (34) also.
5. Clean all parts with a good quality solvent. Remove any encrusted material with crocus or very fine aluminum oxide cloth. Inspect all parts for excessive wear and/or damage. Replace any worn or damaged parts. **USE ONLY JORDAN REPLACEMENT PARTS.** *The use of other than genuine JORDAN parts may result in damage to the actuator, personal injury or property damage.*

B. Actuator Reassembly

1. Place the Fastener Seal (35), Diaphragm Stop (33), Diaphragm (32), and Diaphragm Plate (29 & 31) on the Actuator Bolt (34) in order. Align the Diaphragm (32) and Diaphragm Plate (29) such that one of the formed bosses on the Diaphragm Plate is lined-up with one of the bolt holes in the Diaphragm. Assemble and tighten the two locknuts (36) on the actuator bolt (34), taking care that they are locked together, and that the alignment between the diaphragm and the plate is maintained.
2. Place the Diaphragm Assembly (from step 1) on the Upper Actuator Case (40), (half with the control line connection) with the Diaphragm Plate (29) up. Place the Range Springs (30) on the Diaphragm Plate (29) so that they nest over the formed bosses. Place the Lower Actuator Case (26), (half with the Adaptor Plate (25)), so that the six bolts (28) nest in the Range Springs. The Range Springs must also remain nested over the bosses in the diaphragm plate.
3. Replace four of the Actuator Bolts and Nuts (37, 4) at 90° increments and tighten finger-tight. Thread the Actuator Stem (24), (with the Stem Adapter (19) and Stem Locknut (20)) and Anti-Rotation Device(23) onto the Actuator Bolt (34) until the shoulder on the Actuator Stem (24) contacts the

- Adapter Plate (25). Some spring compression should be felt.
4. Replace the remaining Actuator Bolts and Nuts and tighten evenly across the actuator case.
 5. Reassemble the Actuator Assembly to the Yoke (10) using the four stroke plate bolts (27).
 6. Reconnect the Upper Stem Adapter (19), Jam Nuts (20), and Anti-Rotation Device (23) to the Valve Stem (42) using the Stem Connector Halves (13), the Stem Connector Bolt (7), Lock washer (15) Travel Pointer (14), and Nut (18).
 7. Adjust the spring pre-load following the instructions in the Spring Adjustment section of this I&M.

Valve Stroke Adjustment

1. Loosen the Stem Connector Nut (18) only enough to allow the Stem Adapter (19) to rotate. DO NOT REMOVE the Stem Connector (13). Proper positioning of the Valve Stem (42) and the Stem Adapter (19) must be maintained while adjusting the seats.
2. For Direct Acting (Air to Close) Valves: Loosen jam nuts (20), turn the Actuator Stem (24) counter-clockwise until the Range Springs (30) are slightly compressed. This insures that the Actuator Stem is in its fully upward position. To confirm that the Actuator Stem is fully stroked up, check that it *cannot* be easily rotated without a wrench.
3. For Reverse Acting (Air to Open) Valves; Apply an air pressure of approximately 5 psi above the maximum range pressure (ex. 20 psi for 3-15 psi range) to the actuator. This insures that the Actuator Stem (24) is in its full downward position. To confirm that the Actuator Stem (24) is fully stroked down, check that it *cannot* be easily rotated without a wrench.
4. Check the alignment of the orifices in the Disc (48) and Plate (47). The orifices must be in the open position and in perfect alignment. If the orifices are not in proper alignment, loosen the Stem Locknut (18) and thread the Stem Adapter (19) into, or out of, the Actuator Stem (24), which will move the Disc (48) up, or down, on the Plate (47).
5. After the proper alignment has been obtained, tighten the Jam Nuts (20), and Stem Connector Nut (18) against the end of the Actuator Stem (19). Re-check the seat adjustment. Repeat Step 4 if necessary.
6. Adjust the spring preload if necessary. See the Spring Adjustment section.

Spring Adjustment

The signal range is preset by Jordan Valve; however, when the valve is installed this range may shift slightly due to pressure drops across the valve. Additionally,

preload adjustment may be required after one of the previous maintenance procedures. *Note: valves are bench set at the factory.* To open at 2 psig over the lowest stated number in the range, please insure that any I/P utilized with this control valve is capable of sufficient output to ensure full valve travel. If desired, the range may be changed to suit your needs by following the instructions below.

1. Remove the air signal line from the actuator and replace with a pressure gauge and an air regulator.
2. Loosen, but do not remove the Stem Connector Nut (18), and Lower Jam Nut (20) (under the Anti-Rotation Device (23)).
3. Adjust the actuator air pressure to just below the starting point of the range and rotate the Actuator Stem (24) until the stem just starts to move. Continue to rotate the Actuator Stem about one-half turn.
4. Remove the air pressure. Gradually increase the air pressure and check at what pressure the valve stem starts to move. Repeat Actuator Stem Adjustment (step 3) if necessary and again check to see if the stem starts to move at the desired pressure.
5. After the preload has been properly adjusted, tighten the Lower Jam Nut (20) and the Stem Connector Nut (18) and reattach the control air signal line.

Changing Valve Action

The action of a MK75 may be changed from DIRECT ACTING to REVERSE ACTING, or vice versa, as follows:

6" Valves - Rotate both the Disc (2) and the Plate (1) together 180°. Check the valve stroke and orifice alignment and adjust, if required, as outlined in the Valve Stroke Adjustment section.

8" - Rotate the Disc (2) on the Plate (1) 180°. Check the valve stroke and orifice alignment and adjust, if required, as outlined in the Valve Stroke Adjustment section.

Ordering Spare Parts

Use only genuine Jordan Valve parts to keep your valve in good working order. So that we can supply the parts, which were designed for your valve, we must know exactly which product you are using. The only guarantee to getting the correct replacement parts is to provide your Jordan Representative with the valve serial number. This number is located on the valve identification tag. If the serial number is not available, the parts needed for your valve might be determined using the following information: Model Number, Valve Body Size, Seat Material and Cv Rating, Spring Range and Set Point, Trim Material, Part Name - Number and Quantity.

NOTE: Any parts ordered without a valve serial number that are found to be incorrect are subject to up to a minimum 25% restock charge when returned.

Illustration and Parts List (6" - 8")

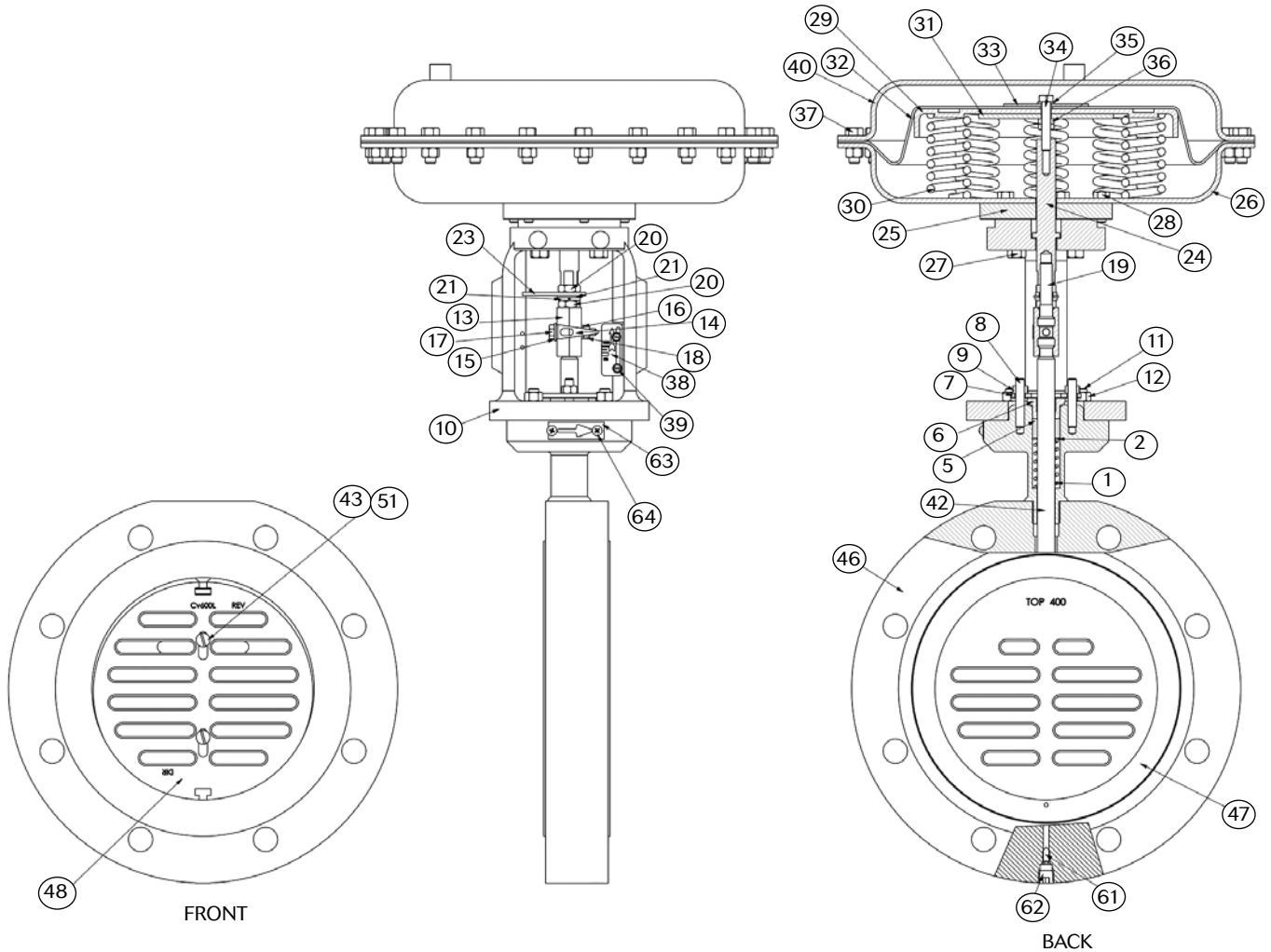

Item	Description	Quantity	Item	Description	Quantity
1	Packing Spring	1	27	HHCS, 3/8-16x1.5	4
2	Packing Retainer	1	28	HHCS, 5/16-18x0.875	6
5	Packing	1	29	Diaphragm Plate	1
6	Packing Follower	1	30	Spring	8
7	Packing Flange	1	31	Backing Plate	1
8	Stud, 5/16-18x1.75	2	32	Diaphragm	1
9	Nut, 5/16-18	2	33	Diaphragm Stop	1
10	Namur Yoke	1	34	HHCS, 5/16-18x1.75	1
11	Stud	4	35	Fastener Seal	1
12	Nut, 3/8-16	4	36	Jam Nut, 5/16x18	2
13	Stem Connector	2	37	HHCS, 3/8-16x1.0	22
14	Travel Ind. Pointer	1	38	Travel Scale	1
15	Washer	1	39	Sheet Metal Screw, 6-32x3/8	2
16	Lock Washer	1	40	Upper Actuator Case	1
17	HHCS, 1/4-20x1.5	1	42	Lower Stem	1
18	Nut, 1/4-20	1	43	Shoulder Screw	2
19	Upper Stem Adaptor	1	46	Body/Bonnet Assembly	1
20	Jam Nut, 7/16-20	2	47	Plate	1
21	Washer	1	48	Disc	1
22	Lock Washer	1	51	Wave Spring	4
23	Anti-Rotation Plate	1	61	CPSS	1
24	Actuator Stem	1	62	Pipe Plug	1
25	Adaptor Plate	1	63	Flow Arrow	1
26	Lower Actuator Case	1	64	Drive Screw	2