



JORDAN VALVE

3170 Wasson Road • Cincinnati, OH 45209
Phone 513.533.5600 • Fax 513.871.0105 (f)
jordan@richardsind.com • www.jordanvalve.com

I & M Mark 575 Series

Installation & Maintenance Instructions for the Mark 575 Back Pressure Regulator

Warning: Jordan Valve Pressure Regulators must only be used, installed and repaired in accordance with these Installation & Maintenance Instructions. Observe all applicable public and company codes and regulations. In the event of leakage or other malfunction, call a qualified service person; continued operation may cause system failure or a general hazard. Before servicing any valve, disconnect, shut off, or bypass all pressurized fluid. Before disassembling a valve, be sure to release all spring tension.

Please read these instructions carefully!

Your Jordan Valve product will provide you with long, trouble-free service if it is correctly installed and maintained. Spending a few minutes now reading these instructions can save hours of trouble and downtime later.

When making repairs, use only genuine Jordan Valve parts, available for immediate shipment from the factory.

Diaphragm, Stem and Bushing Replacement

1. Loosen jam nut (27) and remove adjusting screw (9). Remove hex bolts (10) and hex nuts (11). Lift upper case assembly (13A) off of valve.
2. Remove spring seat (8) and spring (6).
3. Loosen set screws (17), remove seat set (18) and gasket (14), and set aside.
4. Grasp upper diaphragm plate (7) and lift assembly up and out of the body.
5. Remove packing flange (25), follower (24), and associated cap screws. Remove old stem bushing (32) and discard. Insert new bushing, replace follower, packing flange and secure with cap screws.
6. Secure the lower diaphragm plate (3) and remove the upper diaphragm plate (7). Remove and discard the old diaphragm (19). To avoid having to perform stroke adjustment, mark stem (5) with a sharpie or grease pencil at the bottom of jam nut (28). Loosen jam nut (28). Remove stem and jam nut, then transfer mark from the old stem to the new stem. Thread jam nut (28) onto new stem (5), then thread new stem into lower diaphragm plate (3). Ensure the reference mark is just below the jam nut (28).
7. Place new diaphragm (19) onto Lower Diaphragm Plate (3). Thread Upper Diaphragm Plate (7) onto Lower Diaphragm Plate (3) and tighten securely.
8. Lubricate and Insert Stem (5) into Body/Bonnet (1).
9. Replace spring (6) and spring seat (8).
10. If replacing seats, proceed to Section B. If existing seats are being used, replace gasket (14), seat set (18) and replace set screws (17).

11. Carefully center upper case assembly (13A) onto diaphragm and align bolt holes with those in lower case (2). Fasten with Hex bolts (10) and hex nuts (11). Cross tighten bolts in four stages to 85 ft/lbs.
12. Reinstall jam nut (27) and adjusting screw (9).

Seat Set Assembly & Stroke Adjustment

1. Place the Plate (18) on a clean, flat surface, lapped side up.
2. For 3" Valves Only: Install Disc Guides (15) onto Plate (18), using FHMS (16) and loosely tighten. Carefully place Disc (29) onto Plate (18), align slots in the open position, then securely tighten FHMS (16).
3. For 4" & 6" Valves Only: carefully place Disc (29) onto Plate (18), and install Guide Screws (16) and Guide Washers (not shown).
4. Seats will be used with the Disc (29) "TOP REV" facing up
5. Place the assembled seat set into the body (the gasket will be installed after stroke is set), with the "T" head on the Stem (5) engaging the "T" slot on the Disc (29).
6. Install the Spring Housing (13A) with two Hex Bolts (10) and two Hex Nuts (11). Carefully insert a flat blade screw driver into the bottom "T" Slot on the disc, then raise the disc to the upper stop and check seat alignment at full open. To adjust stroke: remove the two hex bolts and the upper spring case. Withdraw seat set from body, then withdraw stem diaphragm assembly from body. Loosen jam nut (28), then adjust stem (5) insertion into lower diaphragm plate* (3), tighten jam nut (28). Replace to re-check adjustment at full open.

* If disc does not fully open, thread stem (5) further into lower diaphragm plate (3). Thread stem out if disc goes past full open.

Final Assembly

1. Reinsert stem diaphragm assembly back into body, lining up holes in diaphragm (19) with those in the lower case (2).
2. Place Range Spring (6) onto Upper Diaphragm Plate (7). Place Spring Seat (8) onto Range Spring (6). Carefully place Upper Case Assembly from step A.1 over Range Spring, aligning bolt holes in the Upper Case (13A) with those in the Diaphragm (19) and Lower Case (2).
3. Use twelve HHCS (10) and Hex Nuts (11) to fasten upper case assembly; cross-tighten to 85 ft lbs in four stages.
4. Lubricate and insert Body Gasket (14) into Body (1). Insert seat set, then install three CPSSS into Body (1) to retain seat set.
5. Install Jam Nut (27) onto Adjusting Screw (9). Thread Adjusting Screw (9) into Closing Cap (12).

Illustration and Parts List

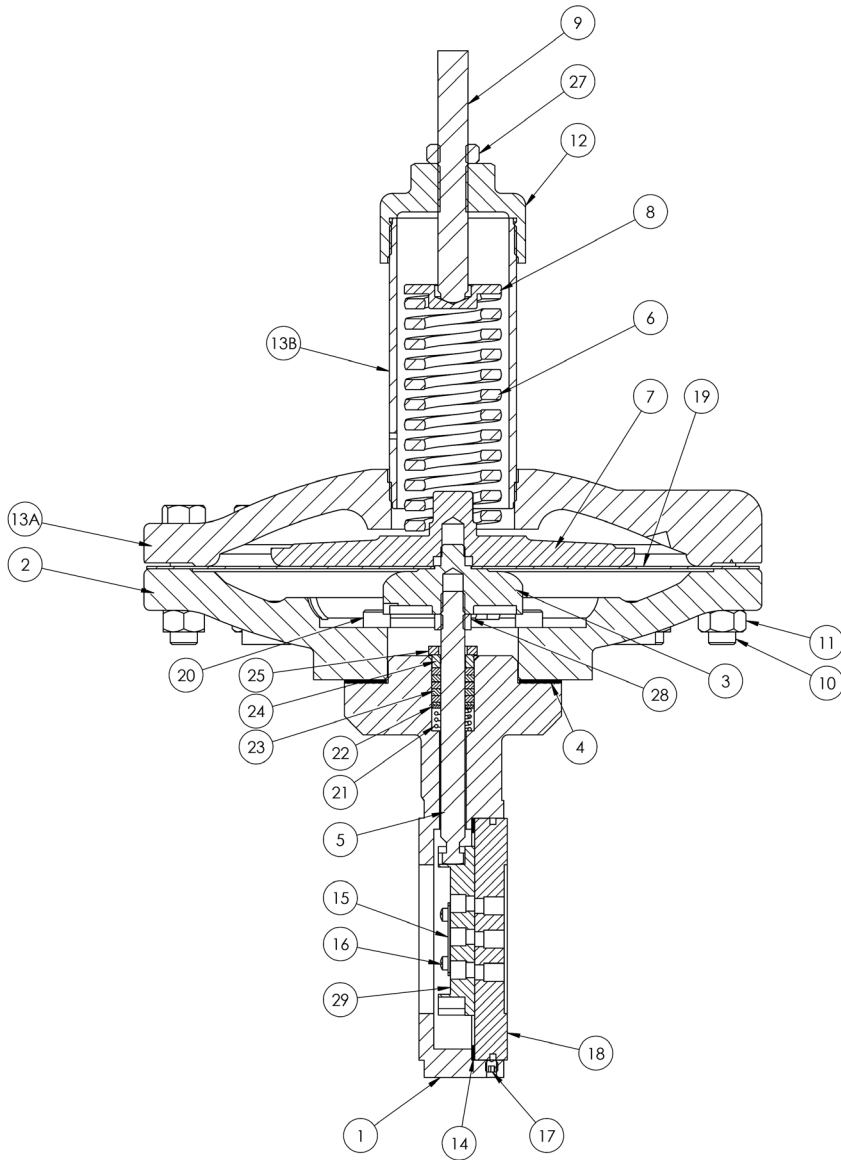

FLOW →

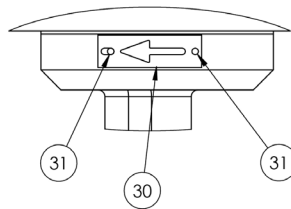
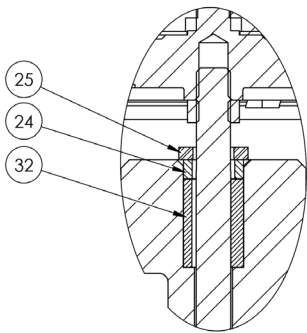

MK575 Detail

Item	Description	1Qty.1
1	Body/Bonnet	1
2	Lower Case	1
3	Lower Diaphragm Plate	1
4	Gasket (Spring Housing/Body)	1
5	Stem	1
6	Spring	1
7	Upper Diaphragm Plate	1
8	Spring Seat	1
9	Adjusting Screw	1
10	HHCS 9/16-12 x 2-1/2"	12
11	Hex Nut 9/16-12	12
12	Closing Cap	1
13	Spring Housing Ass'y	1
13A	Spring Housing	1
13B	Spring Case Tube	1
14	Gasket, Body	1
15	Disc Guide	2
16	FMS 8-32UNC x 3/4"	Varies
17	CPSS 1/4-20 x 1/4"	3
18	Plate	1
19	Diaphragm	1
20	SHCS 3/8-16 x 1-5/8"	6
24	Packing Follower	1
25	Packing Flange	1
27	Hex Jam Nut 5/8-18	1
28	Hex Jam Nut 1/2-13	1
29	Disc	1
30	Flow Arrow	1
31	Screw, Self Tap #2 x 1/8	2
32	Bushing	1