



3170 Wasson Road • Cincinnati, OH 45209 USA
Phone 513-533-5600 • Fax 513-871-0105
info@richardsind.com • www.jordanvalve.com

I & M Mark 608BP

Installation & Maintenance Instructions for Mark 608BP Gas Pressure Regulators

Warning: Jordan Valve Pressure Regulators must only be used, installed and repaired in accordance with these Installation & Maintenance Instructions. Observe all applicable public and company codes and regulations. In the event of leakage or other malfunction, call a qualified service person; continued operation may cause system failure or a general hazard. Before servicing any valve, disconnect, shut off, or bypass all pressurized fluid. Before disassembling a valve, be sure to release all spring tension.

Please read these instructions carefully!

Your Jordan Valve product will provide you with long, trouble-free service if it is correctly installed and maintained. Spending a few minutes now reading these instructions can save hours of trouble and downtime later. When making repairs, use only genuine Jordan Valve parts, available for immediate shipment from the factory.

Ideal Installation

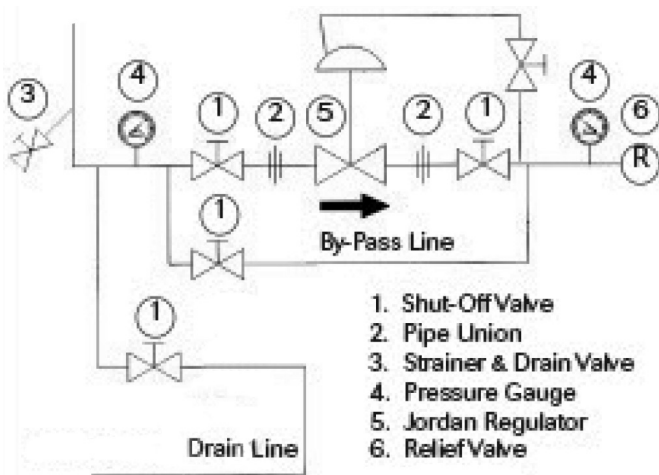

1. To protect the regulator from grit, scale, thread chips and other foreign matter, ALL pipelines and piping components should be blown out and thoroughly cleaned before the installation process begins.
2. Shutoff valves, pressure gauges and by-pass piping should be installed as indicated in the Installation Schematic to provide easier adjustment, operation, and testing.
3. In preparing threaded pipe connections, care should be exercised to prevent pipe sealing compound from getting into the pipe lines. Pipe sealing compound should be used sparingly, leaving the two end threads clean. Jordan recommends Teflon tape.
4. A line strainer should be installed on the inlet side of the regulator to protect pipe from grit, scale and other foreign matter. A 0.033 perforated screen is usually suitable for this purpose. Line strainers are

available from Jordan Valve.

5. The flow arrow on the regulator body must be pointed in the direction of flow. The regulator may be installed in any position. The actuator may be rotated to any position relative to the body (see sizing.) Loosen the union nut and position the actuator. Pull the union nut up hand-tight, then tighten $\frac{1}{4}$ turn. (The union nut is 8-sided and may be used as a guide.)
6. Provisions are provided to vent the case from the top or bottom by a $\frac{1}{4}$ " pipe tap opening. One opening is plugged, the other has a screened (bug) vent. Reverse these if it is desired open vents should point downward; a street elbow can be used if needed. Some installations will require that this vent be piped to some location external to the regulator. When remote piping is used, $\frac{1}{4}$ " size is adequate. NEVER BLOCK OFF THE VENT LINE. Follow local regulations.
7. Connect one end of a $\frac{1}{4}$ " control line to the $\frac{1}{4}$ " NPT tapped opening in the underside of the lower spring housing.
8. Connect the other end in a straight run of pipe 3 to 5 feet downstream of the valve.
9. Install a relief valve downstream from the regulator to protect downstream components from over-pressurization. Generally, the setting of the relief valve should be at least 20% greater than the regulator set point. It must have adequate flow capacity to protect the downstream components should the regulator fail to shut off.
10. Operate the regulator within its rated pressure and temperature. The standard Mark 608BP is rated at 150 psig max (inlet or outlet section) at -20 to $+200^{\circ}\text{F}$. Regulator ratings and materials of construction are listed on the valve name plate.

Sizing

Refer to the sizing charts for the flow capacity of the regulator under various conditions.

Because of the weight of the diaphragm assembly and friction in the moving parts, there is a difference in the lowest setpoint attainable when the actuator housing is

upright, or inverted. (Upright refers to the spring housing cap pointing vertically up.) Lower set points can be achieved with the housing inverted.

With this information, refer to the flow capacity chart in the Mark 608 Product Bulletin. Always use the smallest orifice diameter possible to reduce outlet pressure variations caused by inlet pressure variations.

Start-Up

1. Fully open the outlet shut-off valve.
2. Slowly open the inlet shut-off valve.
3. Slowly open and close the outlet shut-off valve several times. This fully strokes the valve to insure satisfactory operation.
4. With the outlet shut-off valve open and preferably at a low flow, slowly turn the adjusting screw until the desired pressure is shown on the outlet pressure gauge.
5. To change the controlled pressure, turn the adjusting screw clockwise to increase pressure, and counterclockwise to decrease pressure.

Trouble Shooting

If You Experience Erratic Control:

- Oversizing causes cycling and hunting and reduces the rangeability of the valve. Make certain that your sizing is correct.
- Attempting to exceed flow capacity. Make certain that your sizing is correct.
- Blocked vent line or vent passage in spring housing. Clean.
- Inlet pressure varying greatly. Stabilize or use second regulator to control inlet pressure closer.
- Aspirator blocked. Clean.

If You Cannot Set Outlet Pressure:

- Orifice too large for inlet pressure. Refer to Sizing.
- Improper spring.

If the Valve Will Not Operate:

- Diaphragm ruptured. Replace.
- Adjusting spring broken. Replace.
- Improper spring setting. Reset.

Maintenance

WARNING: Be sure that there is no pressure in the valve before loosening any fittings or joints. The following steps are recommended:

1. Close the inlet shut-off valve, and by-pass valve.
2. Back off adjusting screw to allow inlet pressure to open seats.
3. Allow pressure to bleed off through downstream

pipng.

4. When the inlet pressure gauge indicates no pressure in the line, close the outlet shut-off valve.

Refer to the drawings for the proper orientation of the parts and for proper nomenclature.

A. DIAPHRAGM OR GASKET REPLACEMENT

1. Remove all pressure from the line as outlined under WARNING.
2. Remove the compression of the adjusting spring (22) by rotating the adjusting screw (19) counterclockwise.
3. Loosen the spring housing bolts (16) and remove spring housing.

IF DIAPHRAGM IS NOT BEING REPLACED, SKIP STEPS 4 THRU 8.

4. Remove diaphragm subassembly by sliding it away from the valve body to disengage the lever arm (7).
5. Hold the lower diaphragm plate (5) and remove the screw (6), separating the parts.
6. Clean the surfaces on the upper and lower diaphragm plates that the diaphragm (3) seats against. Clean and degrease the threads on the lower diaphragm plate and the screw. (Degrease with Loctite primer T.)
7. Assemble the upper and lower diaphragm plates to the new diaphragm with the screw. (Apply a few drops of Loctite #290 to the screw threads to lock the parts together.) The hole through the lower diaphragm plate must align with any pair of opposite holes in the diaphragm so that it will properly engage the lever when reassembled into the valve.
8. Clean the flange surface on the diaphragm housing and reinstall the diaphragm subassembly onto the lever arm.
9. Clean the flange surface on the spring housing and install a new gasket. The gasket may be temporarily held in place using a few dabs of grease.
10. Set the spring housing on top of the diaphragm housing. Using a 6" long screwdriver, or similar tool, reach through the spring housing and push the diaphragm down to align the diaphragm holes with the housings' holes.
11. Drop the bolts into place and attach the lockwashers and nuts, finger-right.
12. Continue to push the diaphragm down and snug-up the bolts.
13. Evenly torque the bolts as described in the Torque Procedure Section.
14. Install the spring and adjusting screw. (Adjusting spring per start-up instructions and replace cap.)

B. SEAT INSERT, PLUG, OR ASPIRATOR REPLACEMENT

CAUTION: When replacing a plug or seat insert, the lever must also be replaced to insure shutoff.

1. Remove all pressure from the line as outlined under WARNING.
2. Loosen the union nut (24) and separate the actuator from the body.
3. Inspect the plug (11) and seat insert (26) to determine if replacement is required. Replace if there are signs of wear or uneven seating on either part.
4. To replace the seat, simply unscrew it from the body using a 7/8" thinwall socket wrench. Install the new seat. An anti-seize compound applied to the threads will aid in future removal.
5. To replace the plug, or aspirator (12), disassemble the actuator as described in steps A2, A3, A4.
6. Remove the two screws (9) fastening the lever arm bracket (8) to the diaphragm housing and lift out the lever arm bracket with the lever.
7. Inspect aspirating hole in aspirator to be sure it is clean. Remove and replace aspirator if stem guide bores are worn. Remove and replace plug.
8. Remove the screws from the lever arm bracket and clean the threads. Degrease with Loctite Primer T. Also clean and degrease the tapped holes in the diaphragm housing.
9. Remove the pin (10), replace the lever and reassemble with the screws.
10. Apply a drop of Loctite #290 to each screw and reinstall the lever arm bracket. Align the slot in the plug's stem with the new lever arm and tighten the pivot bracket's mounting screws. Check for free movement. Be certain that there is a gasket (29) between the aspirator flange and the diaphragm housing, and a gasket (30) in the body cavity where the aspirator fits.
11. Re-attach body and actuator with the union nut (being careful to align the aspirator tube to the slot in the body). Pull up hand-tight, then tighten further 1/4 turn. (The union nut is 8-sided and may be used as a guide).
12. If lever arm was replaced, apply 25-150 psi pressure through outlet. This will set linkage and prevent overpressure (in operation) from bending the linkage and causing set point changes. Seat leakage may be checked by observing any leakage from inlet.

C. SPRING REPLACEMENT

1. To replace a spring, remove the cap (21) and the adjusting screw (19). Then remove the spring.

CAUTION: If a different range spring is being installed, be sure the proper adjusting screw is used (the 3.5 psi range uses a different adjusting screw.) Failure to observe this caution could result in valve damage or failure to shut off. It is recommended that a new tag be issued for this valve with correct spring range.

2. Reinstall spring and adjusting screw. Adjust spring per startup instructions. Replace cap.

D. DIAPHRAGM OR SPRING HOUSING REPLACEMENT

CAUTION: If the spring housing is to be replaced, the lever must be replaced to insure shutoff.

1. Remove all pressure from the line as outlined under WARNING.
2. Remove the compression of the spring (22) by rotating the adjusting screw (19) counterclockwise.
3. Loosen the spring housing bolts (16) and remove spring housing.
4. Remove diaphragm subassembly by sliding it away from the valve body to disengage the lever arm (7).
5. Remove the two screws (9) fastening the lever arm bracket to the diaphragm housing and lift out the lever arm bracket with the lever arm.
6. Remove the screws from the lever arm bracket and clean the threads. Degrease with Loctite Primer T. Also clean and degrease the tapped holes in the diaphragm housing.
7. Remove the pin (10), replace the lever arm and reassemble with the screws.
8. Apply a drop of Loctite #290 to each screw and reinstall the lever arm bracket. Align the slot in the plug's stem with the new lever arm and tighten the pivot bracket's mounting screws. Check for free movement.
9. Clean the flange surface on the diaphragm housing and reinstall the diaphragm subassembly onto the lever. (Assembly of a new diaphragm subassembly is covered in A1 thru A7.)
10. If a new spring housing is being used, take the new spring housing and carefully drive a new stop pin (23) into the hole in the housing neck with a hammer. (This serves as a spring adjusting screw stop and must be installed.)
11. Clean the flange surface on the spring housing and reinstall a new gasket (13). The gasket may be temporarily held in place using a few dabs of grease.
12. Set the spring housing on top of the diaphragm housing. Using a 6" screwdriver, or similar tool, reach through the spring housing and push the diaphragm down to align the diaphragm holes with

the housings' holes.

13. Drop the bolts into place and attach the lockwashers and nuts, finger-tight.
14. Continue to push the diaphragm down and snug-up the bolts.
15. Evenly torque the bolts as described in Figure 3.
16. Apply 25-150 psi pressure through valve outlet. This will set linkage and prevent overpressure in operation from bending the linkage and causing setpoint changes. Seat leakage may be checked by observing any leakage from inlet.

Ordering Spare Parts

Use only genuine Jordan Valve parts to keep your valve in good working order. So that we can supply the parts, which were designed for your valve, we must know exactly which product you are using. The only guarantee to getting the correct replacement parts is to provide your Jordan Representative with the valve serial number. This number is located on the valve identification tag. If the serial number is not available, the parts needed for your valve might be determined using the following information: Model Number, Valve Body Size, Seat Material and Cv Rating, Spring Range and Set Point, Trim Material, Part Name - Number and Quantity.

NOTE: Any parts ordered without a valve serial number that are found to be incorrect are subject to up to a minimum 25% restock charge when returned.

Torque Procedure

1. Install all bolts hand-tight.
2. Torque the bolts in order of the bolt pattern to approximately 75 in.-lbs.
3. Re-torque each bolt to 300 in.-lbs., using the same bolt pattern as shown.

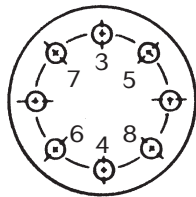

8 bolts
(or multiples)

Illustration and Parts List

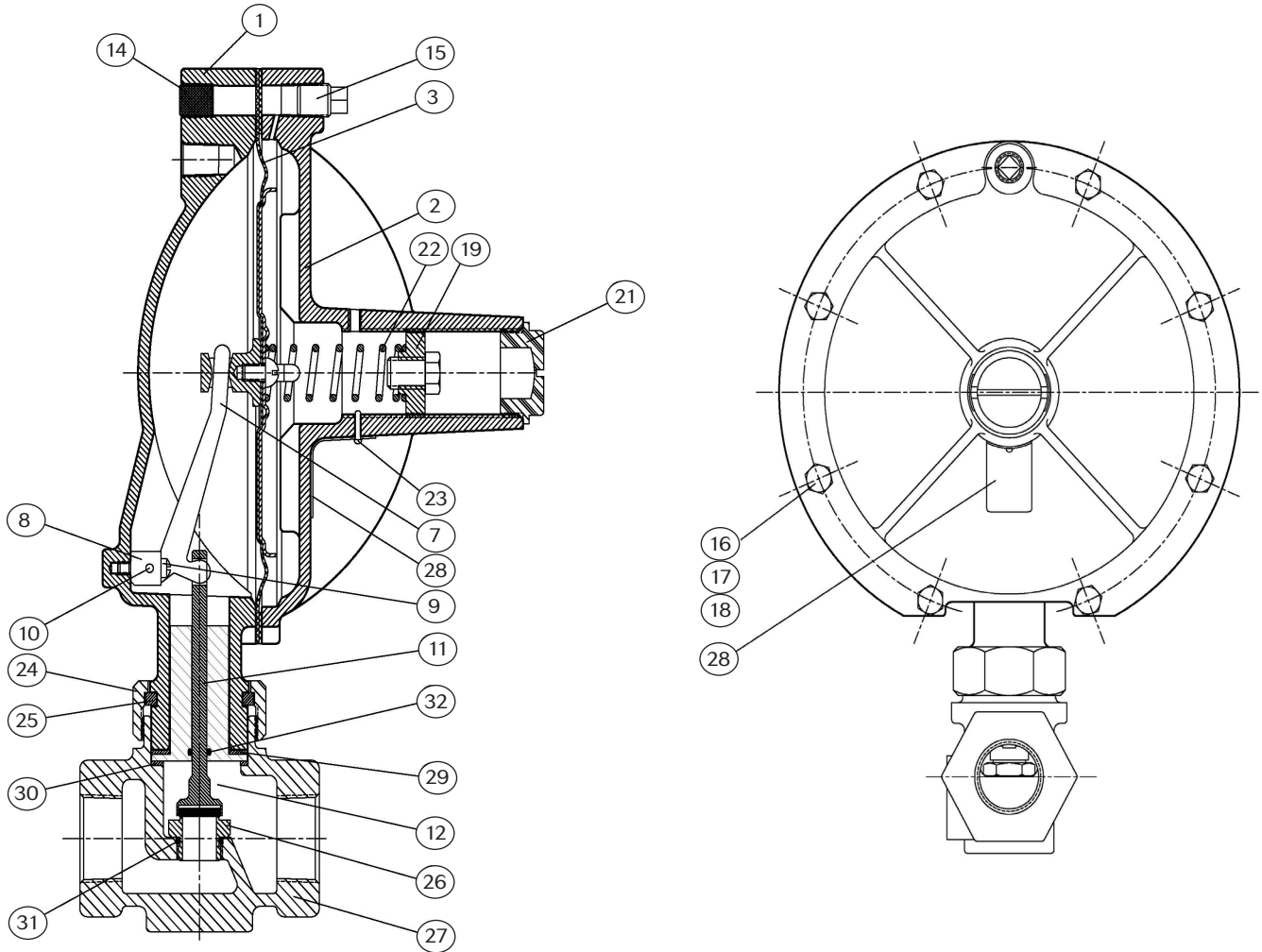

Item	Description	Qty.	Item	Description	Qty.
1	Lower Diaphragm Case	1	19	Adjusting Screw S/A	1
2	Spring Housing	1	21	Cap	1
*3	Diaphragm S/A	1	22	Range Spring	1
7	Lever Arm	1	23	Stop Pin	1
8	Lever Arm Bracket	1	24	Union Nut	1
9	Screw (Lever Arm)	2	25	Retaining Ring	1
10	Dowel Pin	1	*26	Seat Insert	1
*11	Plug	1	27	Body	1
12	Guide for Balanced Plug	1	28	Name Plate	1
14	Vent Screen	1	*29	Gasket (Plug Guide Upper)	1
15	Pipe Plug	1	*30	Gasket (Plug Guide Lower)	1
16	Bolt	8	*31	Orifice O-Ring	1
17	Lockwasher	8	*32	Plug O-Ring	1
18	Nut	8	*	Recommended Spare Parts	