



JORDAN VALVE

3170 Wasson Road • Cincinnati, OH 45209 USA
 Phone 513-533-5600 • Fax 513-871-0105
 info@richardsind.com • www.jordanvalve.com

I & M Mark 686 Series

Installation & Maintenance Instructions for Mark 686 Pressure Regulators (1/4" – 2")

Warning: Jordan Valve pressure regulators must only be used, installed and repaired in accordance with these Installation & Maintenance Instructions. Observe all applicable public and company codes and regulations. In the event of leakage or other malfunction, call a qualified service person; continued operation may cause system failure or a general hazard. Before servicing any valve, disconnect, shut off, or bypass all pressurized fluid. Before disassembling a valve, be sure to release all spring tension.

Please read these instructions carefully!

Your Jordan Valve product will provide you with long, trouble-free service if it is correctly installed and maintained. Spending a few minutes now reading these instructions can save hours of trouble and downtime later. When making repairs, use only genuine Jordan Valve parts, available for immediate shipment from the factory.

Ideal Installation

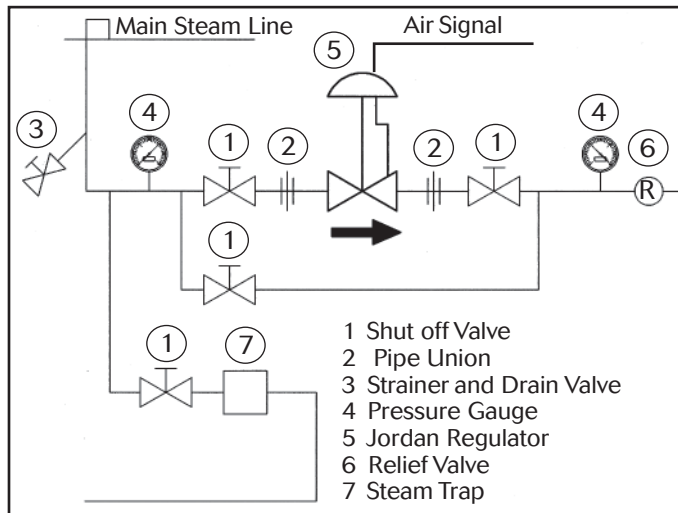

Preferred Installation

- To protect the valve from grit, scale, thread chips, and other foreign matter, all pipe lines and piping components should be blown out and thoroughly cleaned before the valve is installed.
- Shutoff valves, pressure gauges, and bypass piping should be installed as indicated in the Ideal Installation Schematic to provide easier adjustment, operation, and testing.
- In preparing threaded pipe connections, care should be exercised to prevent pipe sealing compound from getting into the pipe lines. Pipe sealing compound should be used sparingly, leaving the two end threads clean. Jordan uses, and recommends, thread sealer Teflon ribbon.

- A line strainer should be installed on the inlet side of the regulator to protect it from grit, scale and other foreign matter. A 0.033 perforated screen is usually suitable. Line strainers are available from Jordan Valve.
- Install the regulator in the highest horizontal line of piping to provide drainage for inlet and outlet piping, to prevent water hammer and to obtain faster regulation.
- The flow arrow on the regulator body must be pointed in the direction of flow. The regulator may be installed vertically or horizontally without affecting its operation.
- For best control, 3'0" straight sections of pipe should be installed on either side of the valve.
- In hot vapor lines, upstream and downstream piping near the regulator should be insulated to minimize condensation.
- If possible, install a relief valve downstream from the valve. Set at 15 psi above the control point of the regulator.
- Expand the outlet piping at least one pipe size if the controlled pressure (downstream) is 25% of the inlet pressure or less. A standard tapered expander connected to the outlet of the regulator is recommended.
- Where surges are severe, a piping accumulator is recommended.
- Operate the regulator within its rated pressure and temperature.

Start-Up

- Fully open the outlet shut-off valve.
- Slowly open the inlet shut-off valve.
- Slowly open and close outlet shut-off valve several times. This fully strokes the valve to insure satisfactory operation.
- With outlet shut-off valve open, slowly increase the air signal until the desired pressure is shown on the outlet pressure gauge.
- To increase the controlled pressure, increase the air signal. Note that the air signal will have to be slightly greater than the desired set point.

Maintenance

WARNING: Be sure that there is no pressure in the valve before loosening any fittings or joints. The following steps are recommended:

1. Close the inlet shut-off valve.
2. Allow pressure to bleed off through the downstream piping. Do not attempt to reverse the flow through the valve by bleeding pressure from the upstream side of the valve.
3. When downstream pressure gauge indicates no pressure in the line, close the outlet shut-off valve.

Refer to the drawing for the proper orientation of the parts and for proper nomenclature.

Troubleshooting

If You Experience Erratic Control:

- Oversizing causes cycling and hunting, and reduces the rangeability of the regulator. Make certain that your sizing is correct.
- Steam traps downstream may need attention.
- Safety valve may be jammed open, disrupting the system. Repair as necessary.
- Excessive foreign matter on seat of plug (3,17)*. Clean them. Inspect seating surface on plug for deterioration.
- Valve stroke may not be moving freely. Check stem (16), bushing (10) or cage bore (2).

If You Experience Downstream Pressure Build-up:

- Seats deteriorated. Inspect for foreign material between plug (3,17) and seat.
- Diaphragm (11) failed. Use elastomer seats for tighter shut-off.

If You Cannot Maintain Regulated Pressure:

- Clogged strainer or lines.
- Inlet pressure low.
- Air signal too low or signal line is leaking or damaged.
- Valve is undersized for rated flow.
- System demand exceeds pump capacity.

* See back page for parts call-out.

Diaphragm Replacement

1. Remove all pressure from the line as outlined under WARNING.
2. Remove the air signal line.
3. Remove the upper diaphragm case (14) by removing hex bolts (15).
4. Lift the diaphragm assembly. This diaphragm assembly consists of the upper diaphragm plate (13), diaphragm (11) and lower diaphragm plate (12).
5. Secure the upper diaphragm plate in a vise. Use a spanner wrench on the lower diaphragm plate and turn counter-clockwise to loosen and remove.
6. Remove the diaphragm, clean the parts and install the new diaphragm in reverse order. Pull the parts up tight when a metal diaphragm is used. When elastomer diaphragms are used, clean and degrease the threads, apply one drop of #290 Loctite to the threads, and assemble. (Loctite Primer T may be used to degrease). Thread the parts together, hand tight, and then tighten 1/8 to 1/4 turn.
7. Clean the diaphragm seating surfaces on the upper case (14) and on the body (1).
8. Unscrew the cage (2) approximately two turns to retract the stem. Place the diaphragm assembly back onto the valve body. (Metal diaphragms nest into the counterbore in the body).
9. Install upper case. Cross tighten bolts (15) evenly with a torque wrench as shown in the chart on page 3.
10. Thread cage (2) back into the body and pull snug.

Seat and Plug Replacement

1. Remove all pressure from the line as outlined in the WARNING.
2. Turn the hex end on the cage (2) counter-clockwise and remove it from the body. The plug (3,17) and return spring (5) will come out with the cap.
3. Remove the seat retaining ring (18), o-ring (20) and seat (19) from the top side using a retaining ring tool. Replace seat, o-ring and retaining ring.
4. Inspect parts for wear and replace as required.
5. Clean all parts in the body and on the cap. Lightly lubricate these surfaces.
6. Reassemble plug spring into cap and check for smooth operation.
7. Install seat with a light coat of Teflon paste on the threads.
8. Install the cap into the body until it bottoms out and tighten.

Torque Procedure

1. Install all bolts hand-tight.
2. Torque the bolts in order of the bolt pattern to a value equal to 1/4 of the recommended torque value.
3. Re-torque each bolt to the recommended value using the same bolt pattern as shown.

Torque Chart for Spring Housing Bolts			
Elastomer Diaphragm		Metal Diaphragm	
Bolt Size	Torque	Bolt Size	Torque
5/16	200 in-lbs	5/16	300 in-lbs
3/8	300 in-lbs	3/8	300 in-lbs

Ordering Spare Parts

Use only genuine Jordan Valve parts to keep your valve in good working order. So that we can supply the parts, which were designed for your valve, we must know exactly which product you are using. Please note the following information on the valve's nameplate:

- Serial Number
- Model and Size
- Body Material and End Connections
- Range
- Diaphragm and Seal Materials

Cross Section View

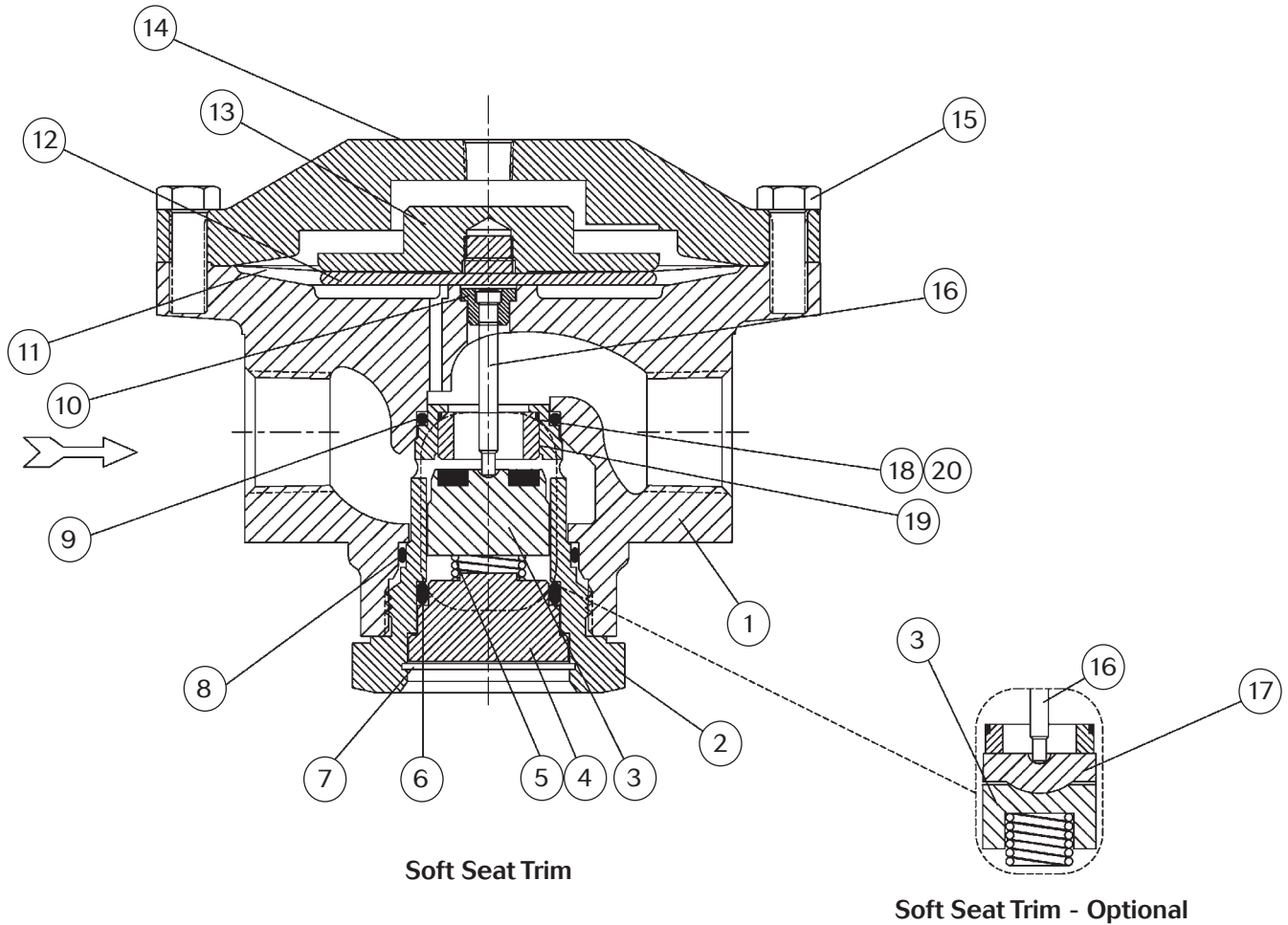

Soft Seat Trim

Soft Seat Trim - Optional

Item	Description	Qty.	Item	Description	Qty.
1	Body	1	11	Diaphragm	1
2	Cage Sub-Assembly	1	12	Lower Diaphragm Plate	1
3	Plug	1	13	Upper Diaphragm Plate	1
4	Closure	1	14	Upper Diaphragm Case	1
5	Return Spring	1	15	Bolt	16 (1 1/4" - 2") 10 (3/4" - 1")
6	Closure O-Ring	1	16	Stem	1
7	Retaining Ring	1	17	Self-Aligning Hard Seat	1
8	Lower Cage O-Ring	1	18	Retaining Ring	1
9	Upper Case O-Ring	1	19	Seat	1
10	Stem Bushing	1	20	Seat O-Ring	1