



JORDAN VALVE

3170 Wasson Road • Cincinnati, OH 45209
Phone 513.533.5600 • Fax 513.871.0105 (f)
info@richardsind.com • www.jordanvalve.com

I & M Mark 2" 695 Series

Installation & Maintenance Instructions for the 2" Mark 695 Internally Piloted Tank Blanketing Valve

Warning: Jordan Valve Pressure Regulators must only be used, installed and repaired in accordance with these Installation & Maintenance Instructions. Observe all applicable public and company codes and regulations. In the event of leakage or other malfunction, call a qualified service person; continued operation may cause system failure or a general hazard. Before servicing any valve, disconnect, shut off, or bypass all pressurized fluid. Before disassembling a valve, be sure to release all spring tension.

Please read these instructions carefully!

Your Jordan Valve product will provide you with long, trouble-free service if it is correctly installed and maintained. Spending a few minutes now reading these instructions can save hours of trouble and downtime later.

When making repairs, use only genuine Jordan Valve parts, available for immediate shipment from the factory.

Ideal Installation

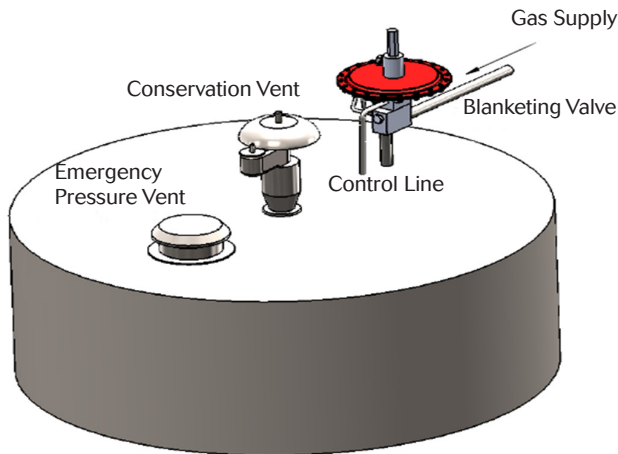

1. To protect the valve from grit, scale, thread chips and other foreign matter, ALL pipelines and piping components should be blown out and thoroughly cleaned before the installation process begins.
2. Shutoff valves, pressure gauges and by-pass piping are optional, and if installed should be in accordance with all applicable codes, standards, and practices. They are recommended to provide easier adjustment, operation, and testing.
3. The flow arrow on the valve body must be pointed in the direction of flow. Ideally, the valve should be installed in the highest horizontal line of piping.
4. Install the relief valve on the tank. Set above the control point of the valve but below the maximum safety limit for the tank.

5. It is strongly recommended that the installer read and be thoroughly familiar with API 2000, Standard Information for Tank Blanketing Regulator Selection before installing and attempting to operate this product.

Control Line

A control line must be installed as follows:

1. Connect one end of 1/2" tubing on the bottom of the main valve actuator.
2. Connect the other end to an appropriate fitting on the tank.
3. DO NOT locate the control line tap in any location where turbulence or abnormal velocities may occur.
4. The control line should be sloped away from the valve.
5. Install a pressure gauge to measure pressure in the tank itself, not in the outlet piping or the control line to aid in setting the valve.

Control line should slope downward toward the tank to prevent condensation buildup.

1. Make the control line as short and straight as possible.
2. Connect the control line to the point where the pressure is to be controlled.
3. Increase tubing size 1/8" for every 10 feet of control line, with setpoints less than 5" w.c. (0,012 bar).

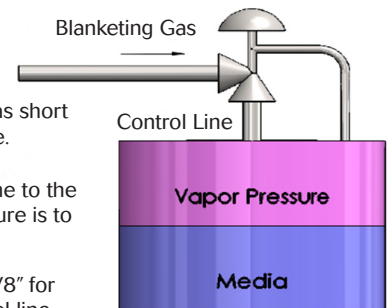

Control Line Piping Recommendation

- Keep the regulator as close to the tank as possible and as high as possible.
- Minimize the length of the downstream pipe coming from the valve.

Mark 695 Series Tank Blanketing Valve

- NEVER reduce the pipe size on the valve outlet to the tank. This line must always be as large as the valve size, or one pipe size larger to assure it does not act as a restriction.
- Any downstream isolation valve after the regulator must be a full port type. The isolation valve cannot act as a restriction.
- The sensing line must be a minimum of 1/2" tube.
- A sensing line isolation valve is recommended. Again, must be full ported.
- Slope the sensing line to the sensing port on the tank.
- Keep the sensing line as short and straight as possible.
- For each 10 feet of sensing line, increase the tube by 1/8". (Especially important on the blanket pressures of less than 5 inches of water column).
- Keep the sensing port on the tank as far removed as possible from the downstream pipe outlet going into the tank.

Start-Up

With the inlet, and bypass shutoff valves closed, and no pressure in the downstream line:

1. Slowly open the inlet valve just enough to start flow through the valve. Observe the tank pressure gauge. Increase the downstream pressure slowly by gradually opening the inlet valve.
2. Do not fully open the inlet valve until you are sure that the regulator has control of the system. Usually, the handwheel on the inlet valve will turn freely when this is achieved.
3. To change the controlled pressure, adjust the set screw (3), and secure with the jam nut (4), and the closing cap (2).

Trouble Shooting

The first step in troubleshooting a piloted pressure regulator is to classify the action of the controlled pressure into one of the following categories:

- A. Under Pressure: Controlled pressure too low; not enough flow or no flow through valve.
- B. Over Pressure: Valve will not close or controlled pressure increases after valve closes.
- C. Pressure Fluctuates: Controlled pressure rises and falls, will not settle out under low loads.

The next step is to determine what could cause the trouble. The third step is to locate and remedy the cause by the process of elimination. Make no assumptions and check the easy ones first. The guide below lists the controlled pressure action, common causes and procedure for checking each cause.

Controlled pressure action UNDER PRESSURE:

- Valve undersized for application. Check capacity required and valve capacity. As described in API-2000.
- Line strainer screen clogged. Blow down strainers or visually check that they are clear.
- Incorrect setting on range spring. Vary the setting and check response.
- Main valve diaphragm or balance diaphragm ruptured. See section on valve maintenance.
- Malfunction of other piping components. Check for leaking safety valves, inadvertently opened or closed valves.

Controlled pressure action OVER PRESSURE:

- Incorrect setting on range spring. Vary the setting and check response.
- Main valve seats leaking. Close inlet shut-off valve, allow downstream pressure to bleed off, close outlet valve and remove loading pressure tubing. Back out adjusting screw on valve until free. Crack open inlet shut-off valve - if the fluid issues from the main valve port, the main valve seats are leaking.
- By-pass shut-off leaking. During period of leakage close outlet shut-off valve, observe downstream pressure gauge
- Under certain circumstances, the vent valve may be open when the tank is not being filled. This may not be caused by an inability to control or seat leakage. The tank may be "outbreathing" due to increases in the temperature of the gas or contents inside the tank.

Controlled Pressure Fluctuates:

- Valve oversized. Check capacity required and valve capacity per API 2000.

Main Valve

Note: All work to the main valve can be accomplished in-line. The only reason to remove the valve is if the location makes it too difficult or dangerous to work on the regulator.

Diaphragm Replacement

Parts Required for this operation: Diaphragm (17), large actuator case gasket (12), and two diaphragm bolt flat gaskets (20).

1. Remove closing cap (2).
2. Mark position of adjusting screw (3) where it meets the jam nut (4).
3. Slightly loosen the jam nut (4) and remove the adjusting screw (3), leaving the jam nut in position.
4. Remove actuator case bolts, lock washers, and flat washers (13)(15)(16). Remove upper actuator case assembly (5).
5. Remove the upper spring guide (6) and range spring (7). Remove and discard the actuator case gasket (12).
6. Remove the diaphragm assembly (17).
7. Remove the diaphragm retaining nut (23), lockwasher (22), two flat washers (21), and upper flat gasket (20) from the diaphragm assembly. Remove the upper diaphragm plate (18), diaphragm (17), lower diaphragm plate (18), and lower flat gasket (27).

If replacing only the diaphragm, reassemble in reverse order using new replacement parts. If replacing internal seals or other parts, continue to section below.

Internal Seal Replacement

Parts Required for this operation: Jordan Valve seal kit consisting of the following parts: o-ring 2-110 for pilot seat (28), o-ring 2-112 for pilot balance (29), o-ring 2-120 for pilot mount (30), o-ring 2-131 for piston-upper (39), o-ring 2-225 for piston - lower(40), o-ring 2-020 for flow plug-inner (35), o-ring 2-223 for flow plug-outer (36), o-ring 2-137 for piston housing (49), o-ring 2-138 for seat ring (45), pilot plug (24), flow plug (37), and seat ring (42).

1. Disconnect the pilot supply line from the pilot body (32) at connector (56). Disconnect the pilot exhaust line from the pilot body (32) at connector (59).
2. Remove the pilot body (32), and discard the o-ring for pilot mount (30). Remove and discard the pilot plug (24), along with its two o-rings (28)(29). Set the pilot return spring (26), lantern ring (27) and the guide pin (25) aside.
3. Remove the six HHCS (47) and lockwashers (48) and lift the piston housing (46) off the main body (1). Discard the piston housing o-ring (49).
4. Remove the piston assembly (38) and set the main

- spring (41) aside. Remove and discard o-rings (39) (40).
5. Remove HHCS (33) and lock-washer (34) from the main piston. Remove and discard o-rings (35) (36), and the flow plug (37). Set the piston (38), HHCS and lockwasher (33)(34) aside.
6. Remove the seat ring HHCS (43) and lockwashers (44). Remove and discard the seat ring (42) and o-ring (45). Lubricate the seat new o-ring and seat ring and reinstall into the body (1).
7. Locate the new flow plug (37), and install o-rings (35) and (36). Place flow plug and o-rings into the piston (38) and secure with HHCS (33) and lock-washer (34). Lubricate and install o-ring (39) onto the piston (38).
8. Lubricate and install o-ring (40) into the piston housing (46). Install main spring (41) and piston assembly (38) into piston housing (46). Lubricate and install piston housing o-ring (49). Place housing and piston onto body (1) and secure with HHCS (47) and lockwashers (48).
9. Lubricate and install o-ring (30) onto pilot mount (31). Replace guide pin (25), lantern ring (27) and pilot return spring(26) into pilot mount (31). Take the new pilot plug (24), lubricate and install o-rings (28) (29). Carefully install pilot plug (24) onto pilot mount (31), taking care to align with guide pin (25) and spring (26). Be careful not to damage o-ring (29) during this process.
10. Install pilot body/lower case (32) onto pilot mount (31). Line up ports and reconnect lines at (56)(59). Top spindle of pilot plug (24) must protrude through the top center hole of the pilot body (32).

Return to Section I above and reassemble in reverse order

Filter/Dripwell Maintenance

Please refer to the documentation for the filter/dripwell that was supplied with your valve for periodic recommended maintenance of this accessory.

Mark 695 Series Tank Blanketing Valve

2" MARK 695 PARTS LIST

The following parts list includes complete part numbers for components of the 2" Mark 695 that are generally replaceable in the field, and are most commonly used. Include the serial number of your actuator in all correspondence regarding replacement parts.

Item NO.	Description	Qty.	Item No.	Description	Qty.
1	BODY	1	34	1/4" LOCK WASHER FOR FLOW PLUG	1
2	CLOSING CAP	1	35	O-RING FOR FLOW PLUG INNNER 2-020	1
3	ADJUSTING SCREW	1	36	O-RING FOR FLOW PLUG 48CV SEAT (OUTER) 2-222	1
4	JAM NUT F/ADJUSTING SCREW	1	37	FLOW PLUG 48Cv	1
5	SPRING HOUSING	1	38	PISTON	1
6	SMALL SPRING GUIDE, RANGE 0.5-5.5 WC	1	39	O-RING FOR PISTON - UPPER 2-131	1
7	RANGE SPRING 0.5-5.4 WC	1	40	O-RING FOR PISTON - LOWER 2-225	1
8	UPPER ACTUATOR CASE GASKET	2	41	MAIN SPRING	1
9	HHCS F/UPPER & LOWER ACTUATOR CASE GASKET	8	42	SEAT RING	1
10	LOCKWASHERS F/UPPER & LOWER ACTUATOR CASE	8	43	1/4-20 HHCS F/SEAT RING	5
11	ACTUATOR CASE	2	44	1/4" LOCKWASHERS FOR SEAT RING	5
12	ACTUATOR CASE GASKET LARGE	1	45	O-RING FOR SEAT RING 2-226	1
13	1/4" HHCS FOR DIAPHRAGM CASE FLANGE	16	46	PISTON HOUSING	1
15	1/4" LOCKWASHERS FOR DIAPHRAGM CASE FLANGE	16	47	HHCS 3/8-16 X 7/8 FOR PISTON HOUSING	6
16	1/4" HEX NUTS FOR DIAPHRAGM	16	48	LOCKWASHER FOR PISTON HOUSING	6
17	DIAPHRAGM	1	49	O-RING FOR PISTON HOUSING 2.5x98mm	1
18	DIAPHRAGM SUPPORT PLATE	2	50	PIPE PLUG, SMALL	1
19	DIAPHRAGM CENTER BOLT, 1/4-20 X 700 X .322H	1	51	PIPE PLUG, LARGE	1
20	FLAT GASKET F/DIAPHRAGM CENTER BOLT	2	52	STRAINER SCREEN - 60 MESH	1
21	LOWER SPRING GUIDE	2	53	3/8" TUBE X 3/8" MNPT THERMOCOUPLE FITTING	1
22	1/4" LOCKWASHER FOR DIAPHRAGM CENTER BOLT	1	54	TUBING 3/8 2 X 24" PCS	48"
23	HEX NUT FOR DIAPHRAGM CENTER BOLT	1	55	AIR FILTER	1
24	PILOT PLUG (SPINDLE)	1	56	ORIFICE HOLDER 1/4 MNPT X 1/4 MNPT - 0.035 ORIFICE	1
25	GUIDE PIN F/PILOT	1	57	CHECK VALVE	1
26	RETURN SPRNG - PILOT	1	58	STREET TEE 1/4F X 1/4M X 1/4F	1
27	LANTERN RING (SPACER) - PILOT BORE	1	59	CONNECTER 3/8 TUBE X 1/4 MNPT	2
28	O-RING FOR PILOT SEAT 2-110	1	60	ELBOW 3/8 TUBE X 1/4 MNPT	1
29	O-RING FOR PILOT BALANCE 2-112	1	61	0.03 ORIFICE - 1/8 MNPT FLUSH PLUG	1
30	O-RING FOR PILOT MOUNT 2-120	1	62	S/H ELBOW 1/4 FNPT X 1/4 FNPT	1
31	PILOT MOUNT	1	63	OPTIONAL INLET PRESSURE GAUGE	1
32	PILOT BODY	1	64	1/4" MNPT PIPE PLUG	1
33	1/4-20 HHCS FOR FLOW PLUG	1	65	SENSING LINE TAG AND PLUG	1

NOTES:

1. SHOWN 90° OUT OF POSITION.

2. O-RING MAT'L CODES: 603-VIT, 622-EPDM, 614 BUNA-N.

3. OPTIONAL ITEM.

4. ITEM ONLY NECESSARY IF ITEM #63 (GAUGE) IS NOT CHOSEN.

2" MARK 695 PARTS VIEW

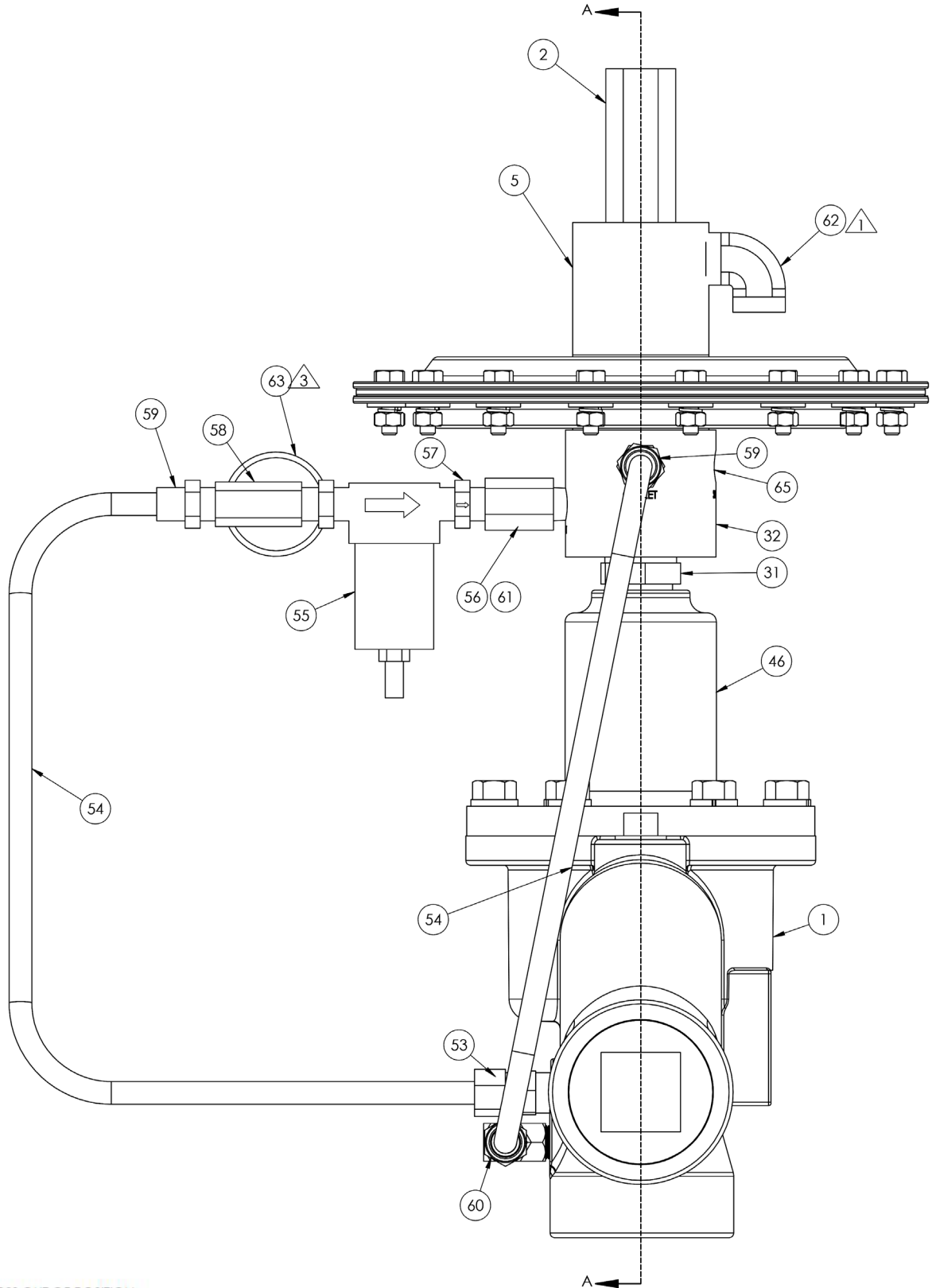

NOTES:

- 1 SHOWN 90° OUT OF POSITION.
- 2 O-RING MATL CODES: 603-VIT, 622-EPDM, 614 BUNA-N.
- 3 OPTIONAL ITEM.
- 4 ITEM ONLY NECESSARY IF ITEM #63 (GAUGE) IS NOT CHOSEN.

2" MARK 695 PARTS VIEW

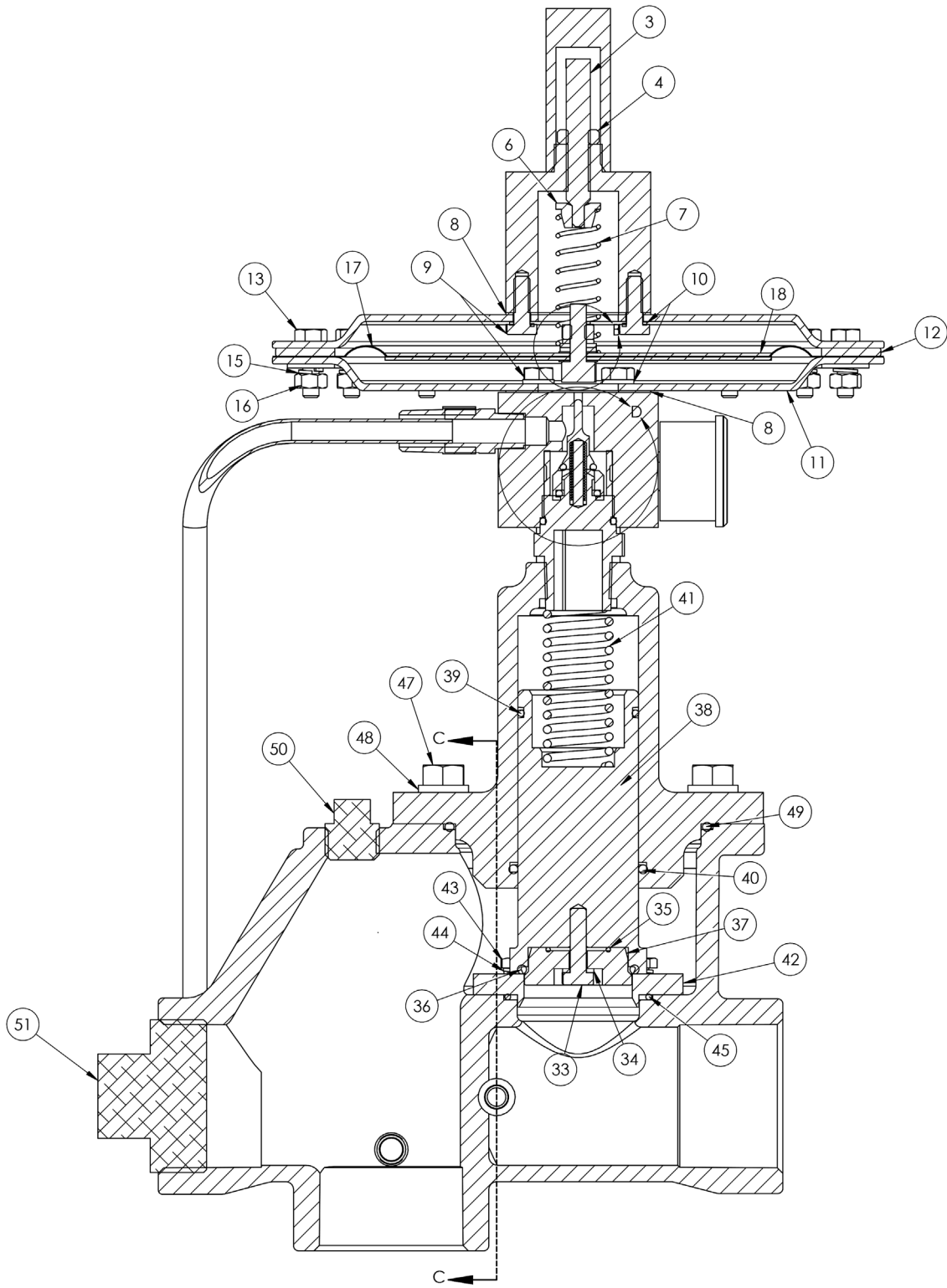

2" MARK 695 PARTS VIEW

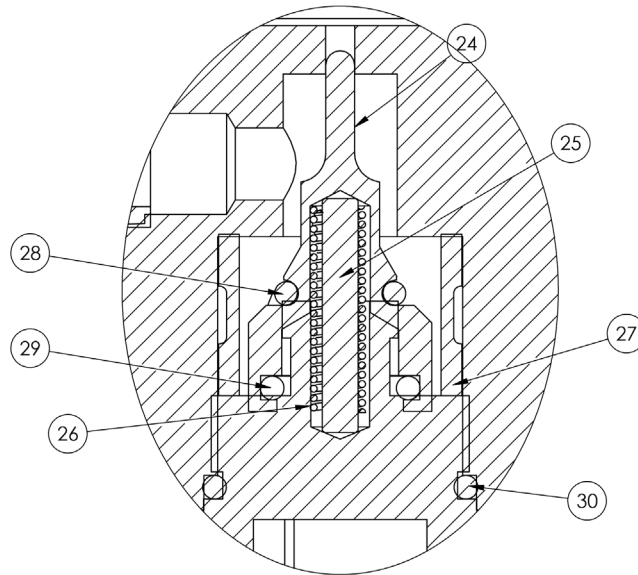

Pilot

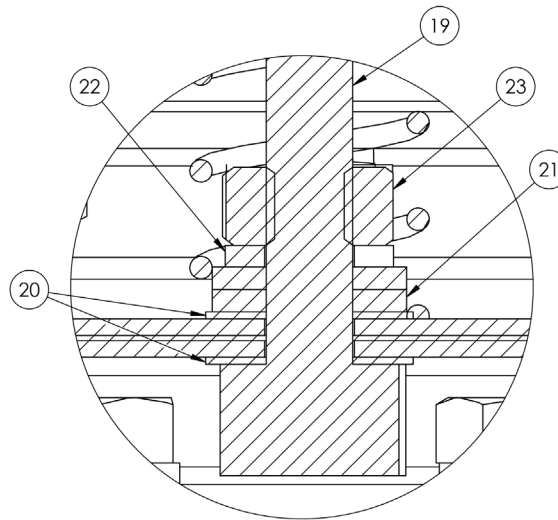

Diaphragm Center Bolt