

VALVE SIZE	FLANGE RATING	DIMENSIONS, INCHES				WGT. LBS.
		A	B	C	D	
2 1/2	125-150#	10.88	18.75	6.95	12.75	165
	250-300#	11.50				
3	125-150#	11.75	18.75	6.95	12.75	185
	250-300#	12.50				
4	125-150#	13.88	19.95	8.00	12.75	215
	250-300#	14.50				

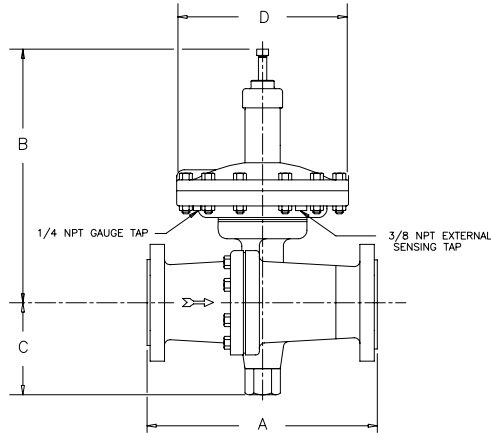

SPECIFICATION DATA	
CUSTOMER	_____
ORDER No.	_____ SERIAL No. _____
TAG No.	_____
VALVE TYPE	_____ QTY. _____
BODY	_____
END CONN.	_____
INLET PRESS.	_____ MAX. $\Delta$ P _____
PRESS. RANGE	_____ SET AT _____
VALVE ACTION: RISE IN PRESSURE TO	<input type="checkbox"/> OPEN <input type="checkbox"/> CLOSE
VALVE SEAT	_____ Cv _____
MISC.	_____
CERTIFIED	_____ DATE _____

MK50 & 60

F.N.:MK50-4

 RICHARDS INDUSTRIES  
CINCINNATI, OHIO  
U.S.A.  
VALVE GROUP

2 1/2-4" MARK 50 & 60  
BACK PRESSURE REGULATOR & PRESSURE REDUCING VALVE.

DRAWN BY	DATE	MK50/60
JLA	2/1/96	
CHECKED BY	DATE	2 1/2-4"