



# JORDAN VALVE

3170 Wasson Road • Cincinnati, OH 45209  
Phone 513.533.5600 • Fax 513.871.0105 (f)  
info@richardsind.com • www.jordanvalve.com

## I & M Mark H-900, H-1500 and H-2500 Series

Installation & Maintenance Instructions for the Mark H-900, H-1500 and H-2500 Series Globe Style Control Valves

**Warning:** Jordan Valve Control Valves must only be used, installed and repaired in accordance with these Installation & Maintenance Instructions. Observe all applicable public and company codes and regulations. In the event of leakage or other malfunction, call a qualified service person; continued operation may cause system failure or a general hazard. Before servicing any valve, disconnect, shut off, or bypass all pressurized fluid. Before disassembling a valve, be sure to release all spring tension.

## INTRODUCTION

Contained in this manual are installation instructions, maintenance and parts information for the Mark H-900, H-1500 and H-2500 Series Valve Bodies. Refer to the appropriate manuals for instructions for the accompanying actuator, positioner and additional accessories.

Only trained or experienced personnel should carry out the operation and installation of all pressure equipment. If you have any questions regarding the equipment, contact your Jordan Valve representative. A serial number identifies each Mark H Series valve and is stamped on the valve body. Please reference this number when communicating with your Jordan Valve representative.

## INSTALLATION

These valves should not be installed in systems that exceed the ANSI specified temperature and pressure ratings. Inspect the valves for shipping, damage and foreign debris when uncrating.

Be sure to use proper hoists with chains or slings when uncrating and handling these valves. Refer to Table 1 in the data sheet for valve body weights.

1. Ensure the pipe is free from welding slag, chips and other debris by blowing out the line prior to installation.
2. Install approved gaskets between the valve body and the pipeline flanges. For butt weld ends on the Mark ET Series trim configuration, remove gaskets and seal rings prior to welding the body into the pipeline.

3. For continuous service applications, Jordan Valve recommends a standard three-valve maintenance bypass be installed. This allows isolation of the valve body without shutting down the pipeline system.
4. The valve should be positioned on the line so the flow direction indicator corresponds to the direction of flow in the pipeline.

**Note: The effectiveness of the pressure-energized seal will be compromised if return flow exists where the downstream pressure exceeds upstream pressure. The result could be leakage or damage to the seal.**

5. The valve body should be positioned with the actuator vertically above it. It is possible to position the valve with an orientation below vertical with support supplied for the actuator. Support for the actuator is required if there is excessive vibration in the line, or if the valve body is positioned more than 45 degrees off vertical.

**PARTS REFERENCE**

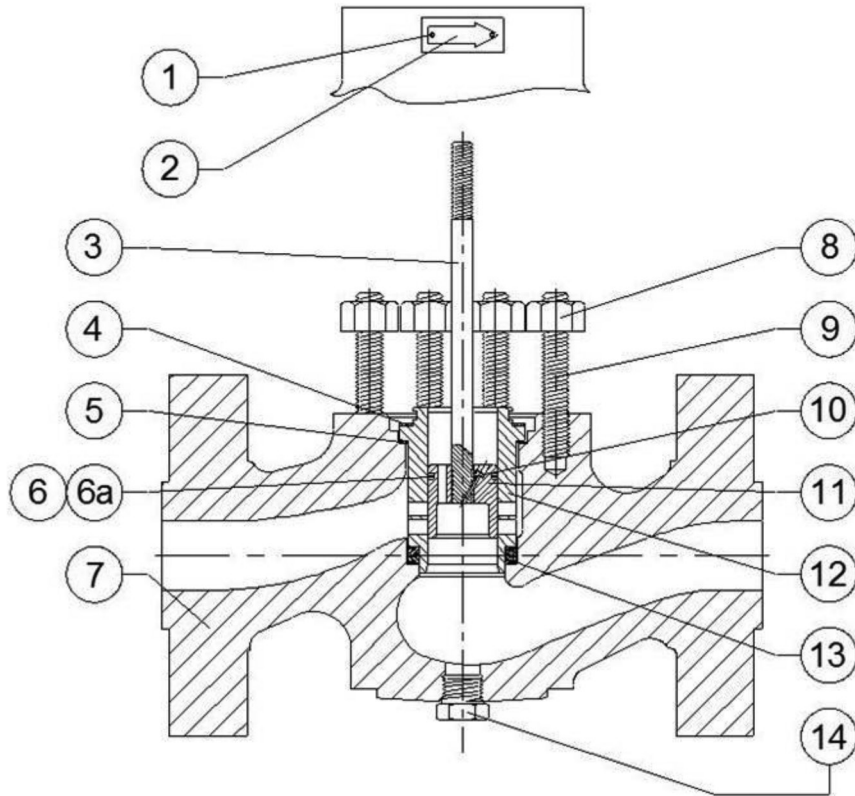

**Figure 1: Mark H-900, H-1500 and H-2500 Valve Body Showing Mark ED Trim**

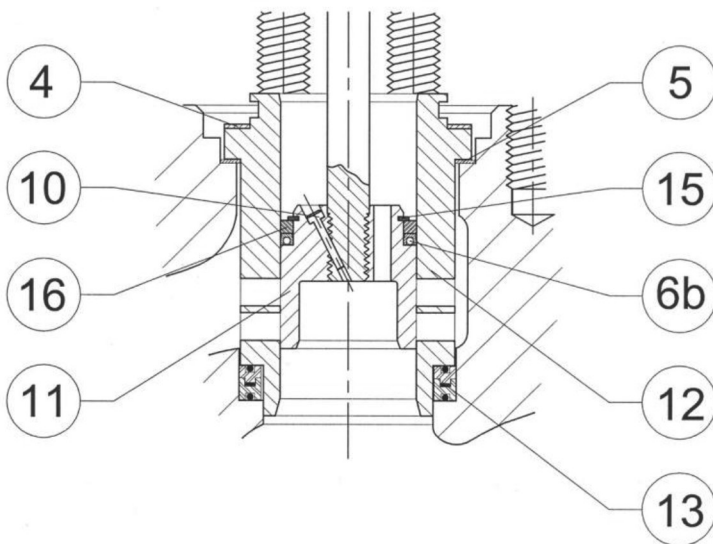

**Figure 2: Mark H-900, H-1500 and H-2500 Valve Body Showing Mark ET Trim**

**Body Parts (Figures 1 & 2)**

Key	Description
1	Drive Screws
2	Flow Arrow
3	Valve Stem
4	Bonnet Gasket
5	Cage Gasket
6	Inner Piston Ring
6a	Outer Piston Ring
6b	Seal Ring
7	Body
8	Hex Nuts
9	Stud Bolts
10	Groove Pin
11	Valve Plug
12	Cage
13	O-Ring Retainer
14	Pipe Plug (Optional)
15	Retaining Ring
16	Backup Ring

**Bonnet Parts (Figure 3)**

Key	Description
17	Bonnet
18	Packing Flange
19	Stud Bolts
20	Hex Nuts
21	Packing Set
22	Packing Spring
23	Packing Spring
24	Packing Box Ring
25	Felt Wiper
26	Packing Follower
27	Pipe Plug
28	Locknut

**Bonnet Parts Not Shown**

Key	Part Name
29	Individual Packing Rings
30	Individual Packing Rings
31	Pipe Nipple for Lubricator Isolating Valve
32	Lubricator / Isolating Valve or Lubricator

## MAINTENANCE

Internal valve components are subject to normal deterioration and must be inspected and replaced as required. The necessity of inspections and replacement of parts will depend on the severity of service conditions. Inspections and maintenance must be carried out on a regular basis.

Before beginning any maintenance, it is important to isolate the control valve and release all pressure contained in the valve body and the actuator.

### Packing Replacement

These instructions refer to the replacement of single or double TFE V-Ring, Garlock and Grafoil packing. Key numbers refer to Figures 1, 2 and 3.

1. Release all loading pressure in the actuator and remove control lines.
2. Remove the cap screws from the stem connector and detach the halves of the stem connector.
3. Unscrew the yoke locknut (Figure 3, Key 28) and separate the actuator from the bonnet (Figure 3, Key 17).
4. Remove the hex nuts (Figure 1, Key 8) and lift the bonnet (Figure 3, Key 17) and valve plug and stem assembly from the valve body (Figure 1, Key 7). Set those components on a clean surface and protect the gasket sealing serrations in the bottom of the bonnet. These serrations are essential for a tight seal between the body and bonnet during reassembly.
5. Remove the bonnet gasket (Figure 1 and 2, Key 4).
6. Loosen the packing flange nuts (Figure 3, Key 20) so the packing becomes loose around the stem.
7. Remove the hex nuts from the valve plug stem (Figure 1, Key 3) and pull the valve plug and stem assembly out of the bonnet. Place this assembly on a protective surface.
8. Remove the hex nuts (Figure 3, Key 20), the packing flange (Figure 3, Key 18), the packing follower (Figure 3, Key 26) and the felt wiper (Figure 3, Key 25).

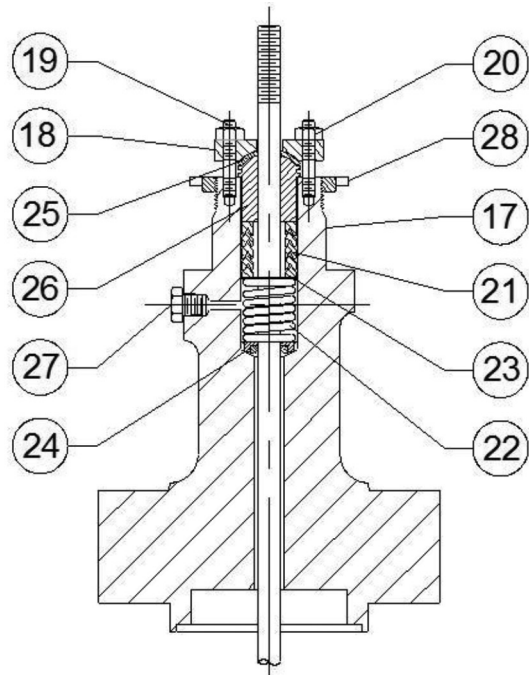

**Figure 3: H-900, H-1500 and H-2500 Bonnet Parts**

**Table 1: Recommended Bonnet Bolt Torque**

Body Size (in)	Bonnet Bolt Torque			
	Class H-900 & H-1500		Class H-2500	
	Ft-lb	N-m	Ft-lb	N-m
3	404	548	404	548
4	540	732	540	732

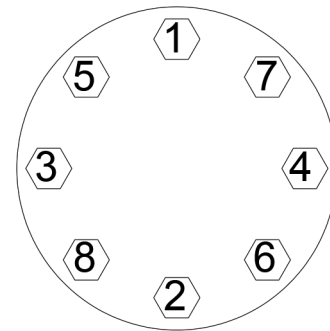

**Figure 4: Typical Bolting Pattern**

**Packing Replacement cont'd**

9. Use a packing hook to remove the packing parts, or push them toward the top of the bonnet using a small rod. Be careful not to scratch the wall of the packing box.
10. Clean the metal packing parts and the packing box, and check the valve stem and packing box surfaces for nicks or scratches. Remove any light scratches with sanding. If damage exists that cannot be sanded out, the valve plug stem and bonnet must be replaced.
11. Install a new bonnet gasket (Figures 2 and 3, Key 4) onto the cage (Figures 2 and 3, Key 12).

**Note: The valve plug assembly of the ED and ET fit inside the cage with tight tolerances. When installing the valve plug assembly be sure not to damage the piston rings or the seal ring (Figures 2 and 3, Keys 6, 6a, 6b).**

**When the bonnet is being mounted, the threads of the valve plug stem will slide through the packing box. If the packing has been installed, carefully attach the bonnet to avoid cutting the packing on the stem threads.**

12. Insert the valve plug assembly in the cage, mounting the bonnet onto the body. Ensure that the leak-off piping (or pipe plug, Figure 3, Key 27) is facing downstream.
13. Apply lubricant to the body stud bolts (Figures 1 and 2, Key 9) and the hex nuts (Figures 1 and 2, Key 8). Thread the nuts onto the body stud bolts using good bolting practices. Refer to Table 1 for proper bolt torques and tighten the nuts in a criss-cross pattern (See Figure 4). When the control valve assembly reaches operating temperature, repeat the procedure. Proper tightening of the bonnet nuts ensures a positive sealing of the cage seals and the spring seal.

**Note: Repeating the bolting pattern may be necessary since tightening one nut may loosen an adjacent nut. The body-to-bonnet seal will be complete when none of the nuts will turn at the recommended torque.**

14. Refer to Figure 3 and arrange the packing parts as outlined. Slide the new packing carefully over the valve plug stem, and ensure that the packing parts are not damaged by the threads of the valve plug stem.
15. Reinstall the packing flange and hex nuts (Keys 18 and 20). Tighten the hex nuts until the shoulder of the packing follower (Key 26) is snug against the packing box.
16. Mount the actuator onto the valve body assembly and reconnect the actuator and valve stem referring to procedures in the appropriate actuator manual.

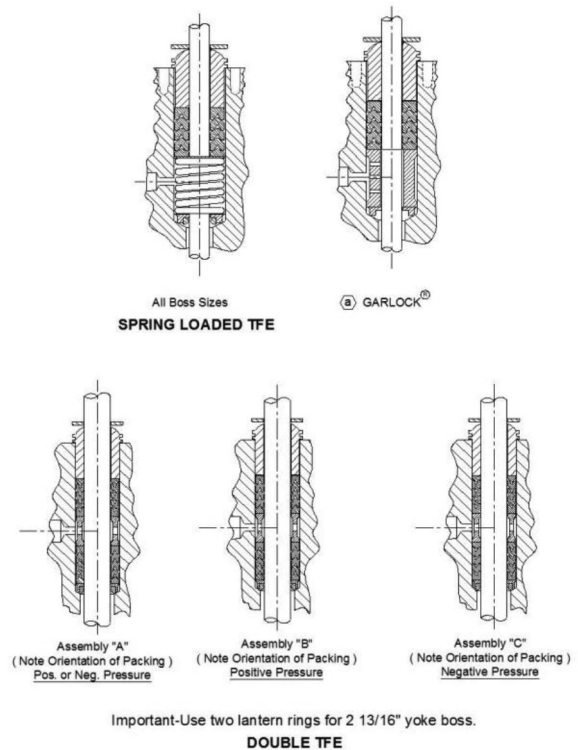

**Figure 5: Packing Arrangements**

See Table 1 for Recommended Torque Values

**GARLOCK is a registered trademark for packings, seals, gaskets and other products of Garlock.**

## Trim Maintenance

Refer to this section for instructions regarding disassembly, replacement of valve plug parts, grinding metal seats and assembly of the valve body as required when replacing trim.

During trim maintenance, always replace the gaskets (Keys 4 and 5). With Mark ET trim, also replace the seal ring (Key 6b).

### Disassembly

1. Complete steps 1 through 6 in the section titled "Packing Replacement".
2. Lift out the cage (Key 12) and cage gaskets (Key 5). If the cage is stuck, insert a blunt tool into the groove around the top of the cage and pry it free.
3. Complete the required maintenance following instructions in the sections "Replacing Valve Plug Parts", "Lapping Metal Seats", or "Assembly" as appropriate.

### Replacing Valve Plug Parts

These instructions are for the TFE V-ring packing. Grafoil and Garlock packing is also available and is supplied with complete replacement instructions.

**Note: Do not use an old stem with a new valve plug. Using an old stem would require drilling a new groove pin hole, and doing so would weaken the stem.**

1. To replace the valve plug stem (Key 3), begin by driving out the groove pin (Key 10) and removing the stem.
2. Insert the new stem, threading it completely into the valve plug (Key 11). Ensure that all threads are engaged.

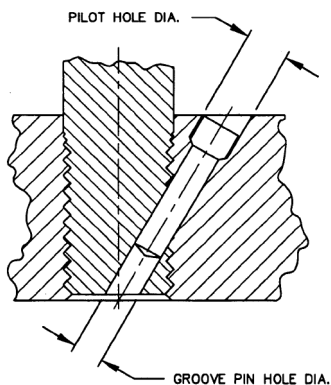

3. Refer to Table 2 and drill the proper sized groove pin hole through the stem. Insert the groove pin which fastens the assembly together.
4. To replace the valve plug rings follow the instructions appropriate for your trim configuration:
  - 4.1. **Mark ED Trim:** remove both piston rings (Keys 6 and 6a) and replace them if they show damage or uneven wear. Install the rings while avoiding excessive bending. Slip the ring with a straight cut over the valve plug and insert the ring into the groove. The ring with the stepped cut slips over the valve plug. Rotate the rings in the groove until the two cuts are in opposite sides of the groove.
  - 4.2. **Mark ET Trim:** Raise the end of the retaining ring (Key 15) using a screw driver. Rotate the plug and lift the ring out and up. Avoid scratching any plug or ring surfaces. Remove the metal backup ring (Key 16) and TFE seal ring (Key 6b). Refer to Figure 6 and install the seal ring for proper flow direction. Install the metal backup ring. Insert one end of the retaining ring (Key 15) into the groove of the valve plug. While turning the plug, press the ring into the groove, being careful not to scratch the valve plug and retaining ring.
5. Continue with procedures for "Lapping Metal Seats" or "Assembly" as required.

**Table 2: Drill Size for Groove Pins**

Port Size		Valve Stem Connection		Drill Size	
in	mm	in	mm	in	mm
1-5/16	33.3	1/2	12.7	3/32	2.4
1-7/8	47.6	1/2	12.7	1/8	3.2
		3/4	19.1	1/8	3.2
2-5/16	58.7	1/2	12.7	1/8	3.2
		3/4	19.1	3/16	4.8
		1	25.4	3/16	4.8
2-7/8	73.0	1/2	12.7	1/8	3.2
		3/4	19.1	3/16	4.8
		1	25.4	1/4	6.4
3-7/16	87.3	3/4	19.1	3/16	4.8
		1	25.4	1/4	6.4

### **Lapping Metal Seats**

While some leakage is expected with any metal-to-metal seating in a valve body, excessive leakage can be improved by lapping or grinding the valve plug and seat ring. Deep nicks should be machined out. A good quality commercial-grade lapping compound should be used.

Apply lapping compound to the valve plug seating surface. During lapping, the bonnet must be bolted to the body and the gaskets (old gaskets may be used) in place in order to keep the valve plug in line with the seat ring. A simple grinding tool can be made using a piece of strap iron fastened to the valve plug stem with nuts.

Rotate the handle in opposite directions to lap the seating surfaces.

After grinding, remove the bonnet and clean the seating surfaces. Test for proper shutoff and repeat the process if necessary.

### **Assembly**

Caution must be used when working around the sealing surfaces. Any nicks or scratches will compromise the sealing ability. Prior to installing the seals, the sealing surface should be wiped with a clean cloth.

1. Install the o-ring retainer (Key 13) into the valve body.
2. Install the cage gasket (Key 5).
3. Install the cage (Key 12) into the valve body.
4. Proceed with steps 11 through 16 of the section titled "Packing Replacement".

## **PARTS ORDERING**

Valves manufactured by Jordan Valve have individual serial numbers, found on the valve nameplate. Please refer to that number when ordering parts or contacting your Jordan Valve Sales Representative. Individual part numbers are listed in the following section. Please include these numbers when ordering replacement parts.

## MARK H-900, H-1500 AND H-2500 SERIES DESIGN VALVE BODIES

Key	Description			Part Number
1	Drive Screws, SST (2 req'd)			1A368228982
2	Flow Arrow, SST			1V106038982
3	Valve Stem			See Following Tables
4	Bonnet Gasket*	Class H-900 and Class H-1500	3" Body Size	10A4154X012
			4" Body Size	10A5457X012
		Class H-2500	3" Body Size	10A4107X012
			4" Body Size	10A4154X012
5	Cage Gasket	Class H-900 and Class H-1500	3" Body Size	10A4155X012
			4" Body Size	10A5458X012
		Class H-2500	3" Body Size	10A4108X012
			4" Body Size	10A4155X012
6	Piston Ring or Seal Ring			See Following Tables
7	Body			See Following Tables
8	Hex Nuts			See Following Tables
9	Stud Bolts			See Following Tables
10	Groove Pin			See Following Tables
11	Valve Plug			See Following Tables
12	Cage			See Following Tables
13	O-Ring Retainer			See Following Tables
14	Pipe Plug (Optional)	Steel for LCC and WCB Bodies		1A771528992
		316SST for CF8M Bodies		1A771535072
15	Retaining Ring			See Following Tables
16	Backup Ring			See Following Tables
17	Bonnet			See Following Tables
18	Packing Flange	2-13/16" Boss, 1/2" Stem	Steel (Standard)	1E944223072
			316 SST	1F380335072
		3-9/16" Boss, 3/4" Stem	Steel (Standard)	1E944823072
			316 SST	1F380435072
19	Stud Bolts (2 Req'd)	2-13/16" Boss, 1/2" Stem	Steel (Standard)	1E944431032
			316 SST	1E944435222
		3-9/16" Boss, 3/4" Stem	Steel (Standard)	1E944931032
			316 SST	1E944935222
20	Hex Nuts (2 Req'd)	2-13/16" Boss, 1/2" Stem	Steel (Standard)	1E944524112
			316 SST	1E944535252
		3-9/16" Boss, 3/4" Stem	Steel (Standard)	1E944624112
			316 SST	1E944635252

**MARK H-900, H-1500 AND H-2500 SERIES GLOBE STYLE CONTROL VALVES**

Key	Description	Part Number	
21	Packing Set	See Following Tables	
22	Lantern Ring or Spring	See Following Tables	
23	Special Washer	See Following Tables	
24	Packing Box Ring	See Following Tables	
25	Felt Wiper	See Following Tables	
26	Packing Follower	See Following Tables	
27	Pipe Plug	Steel, for LCC and LCB Bodies	1A767524662
		316SST for CF8M Bodies	1A767535072
28	Locknut, Steel	2-13/16" Boss, 1/2" Stem	1E807423062
		3-9/16" Boss, 3/4" Stem	1E832723062
29	Packing Ring	See Following Tables	
30	Packing Ring	See Following Tables	
31	Pipe Nipple for Lubricator Isolating Valve	For LCC Bonnets	1D239726232
		For all other Bonnets	1B292738332
32	Lubricator / Isolating Valve	AJ5428000A2	
	Lubricator	0V0873000A2	

\* Recommended Spare Part

**Key 3: Valve Stem\***

ANSI Body Rating	Body Size (In)	Stem Size		Port Size		Part Number
		in	mm	in	mm	
Class H-900 and Class H-1500	3	1/2	12.7	B	B	1K587435162
		3/4	19.1	1-7/8	47.6	1U444635162
	2-7/8	73.0	1K588035162			
	4	3/4	19.1	B	B	1U444635162
Class H-2500	3	1/2	12.7	B	B	1K587235162
		3/4	19.1	2-5/16	58.7	1K588035162
	4	3/4	19.1	1-7/8	47.6	1U444635162
		2-7/8	73.0	1K588035162		

B: Available in both port sizes (Full and Restricted)



MARK H-900, H-1500 AND H-2500 SERIES GLOBE STYLE CONTROL VALVES

**Key 6: Piston Ring (Mark ED) or Seal Ring (Mark ET)\***

ANSI Body Rating	Body Size (In)	Port Size		Mark ED Piston Ring Alloy #25 and 17-4 PH SST 450°F to 800°F (232°C to 427°C)	Mark ET Seal Ring	
		in	mm		Spring-Loaded FEP -425°F to -100°F (-253°C to -73°C)	Spring-Loaded TFE -100°F to 450°F (-73°C to 232°C)
Class H-900 and Class H-1500	3	1-7/8	47.6	10A4214X012	10A4216X022	10A4216X012
		2-7/8	73.0	10A4213X012	10A4215X022	10A4215X012
	4	2-5/16	58.7	10A4204X012	10A4206X022	10A4206X012
		3-7/16	80.6	10A5348X012	10A5351X012	10A5351X022
Class H-2500	3	1-5/16	33.3	10A4205X012	10A4207X022	10A4207X012
		2-5/16	58.7	10A4204X012	10A4206X022	10A4206X012
	4	1-7/8	47.6	10A4214X012	10A4216X022	10A4216X012
		2-7/8	73.0	10A4213X012	10A4215X022	10A4215X012

**Key 7: Body LCC Steel**

ANSI Body Rating	End Connections		Body Size, Inches Without Drain Plug Tapping	
			3	4
Class H-900 and Class H-1500	900 lb	RF	30A5287X032	30A5304X032
		RTJ	30A5291X032	30A5308X032
	1500 lb	RF	30A5289X032	30A5306X032
		RTJ	30A5293X032	30A5310X032
	Butt Weld	80	30A5295X032	30A5312X032
		160	30A5297X032	30A5314X032
Class H-2500	2500 lb	RF	30A4065X032	30A4110X032
		RTJ	30A4067X032	30A4112X032
	Butt Weld	80	30A4069X032	30A4114X032
		XXS	30A4071X032	30A4116X032

**WCB Steel**

ANSI Body Rating	End Connections		Body Size, Inches Without Drain Plug Tapping	
			3	4
Class H-900 and Class H-1500	900 lb	RF	30A5287X012	30A5304X012
		RTJ	30A5291X012	30A5308X012
	1500 lb	RF	30A5289X012	30A5306X012
		RTJ	30A5293X012	30A5310X012
	Butt Weld	80	30A5295X012	30A5312X012
		160	30A5297X012	30A5314X012
Class H-2500	2500 lb	RF	30A4065X012	30A4110X012
		RTJ	30A4067X012	30A4112X012
	Butt Weld	80	30A4069X012	30A4114X012
		XXS	30A4071X012	30A4116X012

\* Recommended Spare Part

MARK H-900, H-1500 AND H-2500 SERIES GLOBE STYLE CONTROL VALVES

**Key 7: Body Cont, CF8M**

ANSI Body Rating	End Connections		Body Size, Inches Without Drain Plug Tapping	
			3	4
Class H-900 and Class H-1500	900 lb	RF	30A5287X052	30A5304X052
		RTJ	30A5291X052	30A5308X052
	1500 lb	RF	30A5289X052	30A5306X052
		RTJ	30A5293X052	30A5310X052
	Butt Weld	80	30A5295X052	30A5312X052
		160	30A5297X052	30A5314X052
Class H-2500	2500 lb	RF	30A4065X052	30A4110X052
		RTJ	30A4067X052	30A4112X052
	Butt Weld	80	30A4069X052	30A4114X052
		XXS	30A4071X052	30A4116X052

**Key 8: Hex Nuts**

**Key 9: Stud Bolts**

Valve Body Material	Temperature Capabilities		Class H-900 and Class H-1500 Body			
	(°F)	(°C)	3" Body		4" Body	
			Key 8: Hex Nuts (8 req'd)	Key 9: Stud Bolts (8 req'd)	Key 8: Hex Nuts (8 req'd)	Key 9: Stud Bolts (8 req'd)
WCB Steel	-20 to 800	-29 to 427	1A440924072	10A5564X012	1A445224072	10A5565X012
LCC Steel	-50 to 650	-45 to 343	1A440924072	10A5564X012	1A445224072	10A5565X012
CF8M	-425 to -325	-254 to -198	1A4409X0012	10A5564X062	1A4452X0022	10A5565X062
	-325 to -50	-198 to -46	1A440935252	10A5564X062	1A445235252	10A5565X042
	-50 to 450 <sup>1</sup>	-46 to 232	1A440924072	1A365631012	1A445224072	10A5565X012
	-50 to 450 <sup>2</sup>	-46 to 232	1A440935252	1A365635222	1A445235252	10A5565X042
	450 to 1000	232 to 538	1A440935252	1A365635222	1A445235252	10A5565X042
	1000 to 1110	538 to 593	1A440935252	1A3656X0012	1A445235252	10A5565X032
Valve Body Material	Temperature Capabilities		Class H-2500 Body			
	(°F)	(°C)	3" Body		4" Body	
			Key 8: Hex Nuts (8 req'd)	Key 9: Stud Bolts (8 req'd)	Key 8: Hex Nuts (8 req'd)	Key 9: Stud Bolts (8 req'd)
WCB Steel	-20 to 300	-29 to 149	1A440924072	1A365631012	1A445224072	1D945231012
LCC Steel	-50 to 650	-45 to 343	1A440924072	10A5563X012	1A445224072	10A4221X012
CF8M	-425 to -325	-254 to -198	1A4409X0012	1A3656X0022	1A4452X0022	1D9452X0032
	-325 to -50	-198 to -46	1A440935252	1A365635222	1A445235252	1D945235222
	-50 to 450 <sup>1</sup>	-46 to 232	1A440924072	1A365631012	1A445224072	1D945231012
	-50 to 450 <sup>2</sup>	-46 to 232	1A440935252	1A365635222	1A445235252	1D945235222
	450 to 1000	232 to 538	1A440935252	1A365635222	1A445235252	1D945235222
	1000 to 1050	538 to 566	1A440935252	1A3656X0012	1A445235252	1D9452X0022

1 Steel (B7) Bolting

2 Strain Hardened SST (B8M) Bolting

MARK H-900, H-1500 AND H-2500 SERIES GLOBE STYLE CONTROL VALVES

**Key 10: Groove Pin, 316 SST\***

Port Size		Valve Stem Connection		ED, ET
in	mm	in	mm	
1-5/16	33.3	1/2	12.7	1V322635072
1-7/8	47.6	1/2	12.7	1V322735072
		3/4	19.1	2V322735072
2-5/16	58.7	1/2	12.7	1V322735072
		3/4	19.1	1V326035072
		1	25.4	1V326035072
2-7/8	73.0	1/2	12.7	1V322735072
		3/4	19.1	1V326035072
		1	25.4	1V334035072

**Key 11: Valve Plug\***

ANSI Body Rating	Body Size (in)	Port Size		Valve stem Connection		ED	ET
		in	mm	in	mm	316 SST	
Class H-900 and Class H-1500	3	1-7/8	47.6	1/2	12.7	20A4148X012	20A4150X012
				3/4	19.1	20A9355X012	20A9357X012
		2-7/8	73.0	1/2	12.7	20A9531X012	20A9533X012
				3/4	19.1	20A4140X012	20A4144X012
	4	2-5/16	58.7	3/4	19.1	20A4094X012	20A4098X012
		3-7/16	87.3	3/4	19.1	20A5338X012	20A5342X012
Class H-2500	3	1-5/16	33.3	1/2	12.7	20A9363X012	20A9365X012
		2-5/16	58.7	3/4	19.1	20A4093X012	20A4097X012
		1-7/8	47.6	3/4	19.1	20A4094X012	20A4098X012
	4	1-7/8	47.6	3/4	19.1	20A9355X012	20A9357X012
		2-7/8	73.0	3/4	19.1	20A4140X012	20A4144X012

**Key 12: Cage**

ANSI Body Rating	Body Size (in)	Port Size		Equal Percentage		Linear	
		in	mm	17-4 PH SST Hardened	316 SST	17-4 PH SST Hardened	316 SST
Class H-900 and Class H-1500	3	1-7/8	47.6	30A4137X012	30A4138X012	30A4131X012	30A4132X012
		2-7/8	73.0	30A4134X012	30A4135X012	30A4128X012	30A4129X012
	4	2-5/16	58.7	30A5335X012	30A5336X012	30A5329X012	30A5330X012
		3-7/16	87.3	30A5334X012	30A5333X012	30A5326X012	30A5327X012
Class H-2500	3	1-5/16	33.3	30A4091X012	30A4092X012	30A4086X012	30A4087X012
		2-5/16	58.7	30A4088X012	30A4089X012	30A4083X012	30A4084X012
	4	1-7/8	47.6	30A4137X012	30A4138X012	30A4131X012	30A4132X012
		2-7/8	73.0	30A4134X012	30A4135X012	30A4128X012	30A4129X012

**Key 13: O-Ring Retainer \***

ANSI Body Rating	Body Size (in)	Upper Retainer 316 SS	Lower Retainer 316 SS	Seal Kits	
				Viton*	HSN
Class H-900 and H-1500	3	13A0295X012	13A0297X012	3H1500-SK-V	3H1500-SK-H
	4	13A0296X012	13A0298X012	4H1500-SK-V	4H1500-SK-H
Class H-2500	3	15A9173X012	15A0295X012	3H2500-SK-V	3H2500-SK-H
	4	15A9174X012	15A0296X012	4H2500-SK-V	3H2500-SK-H

\* Viton is a registered trademark of DuPont Dow Elastomers

**Key 15: Retaining Ring**

ANSI Body Rating	Body Size (in)	Full Sized Trim
Class H-900 and H-1500	3	20A4219X012
	4	10A5350X012
Class H-2500	3	10A4210X012
	4	10A4219X012

**Key 16: Backup Ring**

ANSI Body Rating	Body Size (in)	Full Sized Trim	
		316 SST	316 SST with Alloy #6
Class H-900 and H-1500	3	20A4217X012	20A4217X022
	4	10A5349X012	10A5349X022
Class H-2500	3	10A4208X012	10A4208X022
	4	10A4217X012	10A4217X022

**Key 17: Bonnet**

ANSI Body Rating	Body Size (in)	Stem Size		WCB	LCC	CF8M
		in	mm			
Class H-900 and Class H-1500	3	1/2	12.7	30A7504X012	30A7504X032	30A7504X052
		3/4	19.1	30A5300X012	30A5300X032	30A5300X052
	4	3/4	19.1	30A5317X012	30A5317X032	30A5317X052
Class H-2500	3	1/2	12.7	30A4075X012	30A4075X032	30A4075X052
		3/4	19.1	30A4074X012	30A4074X032	30A4074X052
	4		19.1	30A4119X012	30A4119X032	30A4119X052

\* Recommended Spare Part

## MARK H-900, H-1500 AND H-2500 SERIES GLOBE STYLE CONTROL VALVES

**Key 21: Packing Set\***

Boss Size		Stem Size		Spring-Loaded TFE V-Ring	Double TFE V-Ring (2 req'd)
in	mm	in	mm		
2-13/16	71.4	1/2	12.7	1R290201012	1R290201012
3-9/16	90.5	3/4	19.1	1R290401012	1R290401012

**Key 22: Lantern Ring or Spring**

Boss Size		Stem Size		Spring-Loaded TFE V-Ring		Lantern Ring with Double TFE V-Ring (2 req'd)	
in	mm	in	mm	No. Req'd	Part Number	No. Req'd	Part Number
2-13/16	71.4	1/2	12.7	1	1F125537012	3	1J962335072
3-9/16	90.5	3/4	19.1	1	1F125637012	2	0N028435072

**Keys 23, 24, 25, 26: Packing Parts**

Includes Special Washer, Packing Box Ring, Felt Wiper, Packing Follower

Boss Size		Stem Size		Key 23: Special Washer 316 SST (TFE V-Ring Only)	Key 24: Packing Box Ring		Key 25: Felt Wiper	Key 26: Fol- lower 316 SST
in	mm	in	mm		17-4PH SST	316 SST		
2-13/16	71.4	1/2	12.7	1F125136042	---	1J873235072	1J872706332	1E944335072
3-9/16	90.5	3/4	19.1	1F125036042		1J873335072	1J872806332	1E944735072

**Key 29 and 30: Packing Rings (Set only)**

Boss Size		Stem Size		TFE		Grafoil	
in	mm	in	mm	No. Req'd	Part Number	No. Req'd	Part Number
2-13/16	71.4	1/2	12.7	10	1E319001051	3	1V380201652
3-9/16	90.5	3/4	19.1	8	1E319101051	4	1V239601652

\* Recommended Spare Part



Jordan Valve, a division of Richards Industries

3170 Wasson Road • Cincinnati, OH 45209

513.533.5600 • 800.543.7311 • 513.871.0105 (f)

info@richardsind.com • www.jordanvalve.com