

MK60  
PRESSURE  
REGULATOR

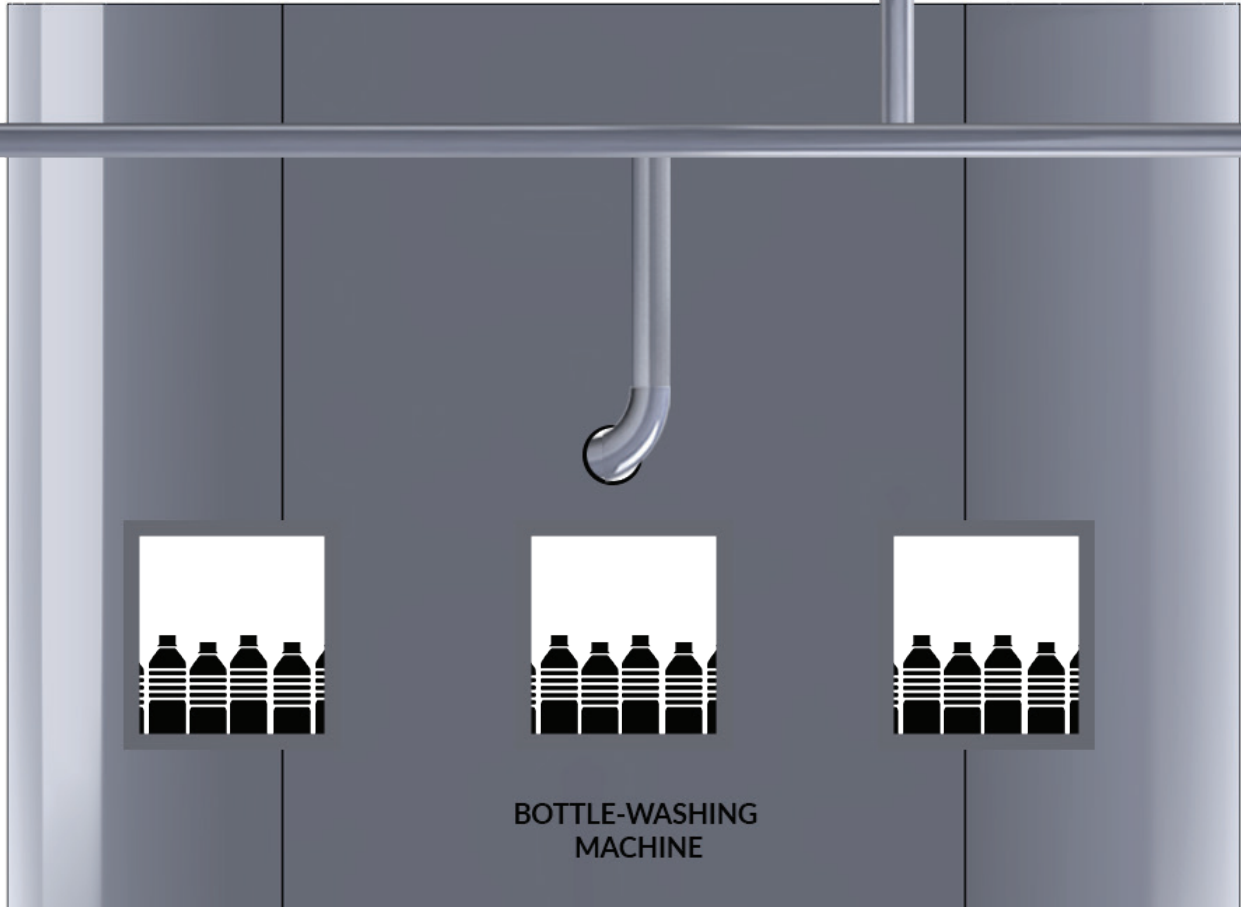
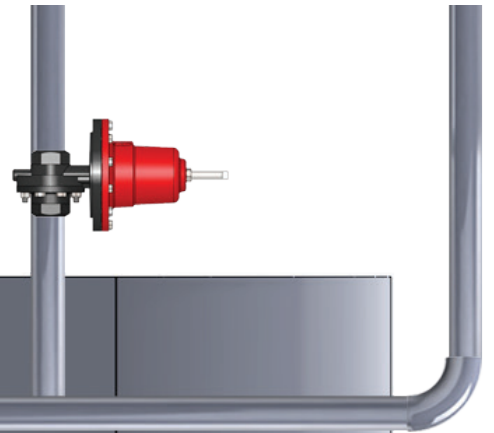

BOTTLE-WASHING  
MACHINE

## BOTTLE-WASHING MACHINE

The above picture is an example of a water bottling plant which has some of our valves fitted. The plant fills 5 million bottles of water every day and has the capability to fill as many as 10.5 million bottles daily, if required. They have several Mark 60 regulators fitted on various water duties.

One Mark 60 is fitted on their bottle-washing machine and is used to control the pressure of the wash water, reducing the pressure from 5 bar (72.5 psi) to 2 bar (29 psi). The valve part cycles 10,000 times per hour, 24 hours a day, 7 days a week.

They used to have to change the diaphragms regularly when they were fitted with metal diaphragms, but now they have changed to Jorlon they change them every 2 years, whether they need changing or not.

A quick calculation would suggest that the valve is seeing over 170 million partial cycles during this time.