

VALVE SIZE	DIMENSIONS, INCHES				WGT. LBS.
	A	B	C	D	
1/2	5.00	5.30	2.04	5.00	11
3/4	5.00	8.79	2.12	6.81	20
1	5.00	8.79	2.12	6.81	20
1 1/2	7.50	16.82	3.12	9.38	68
2	7.50	16.82	3.12	9.38	68

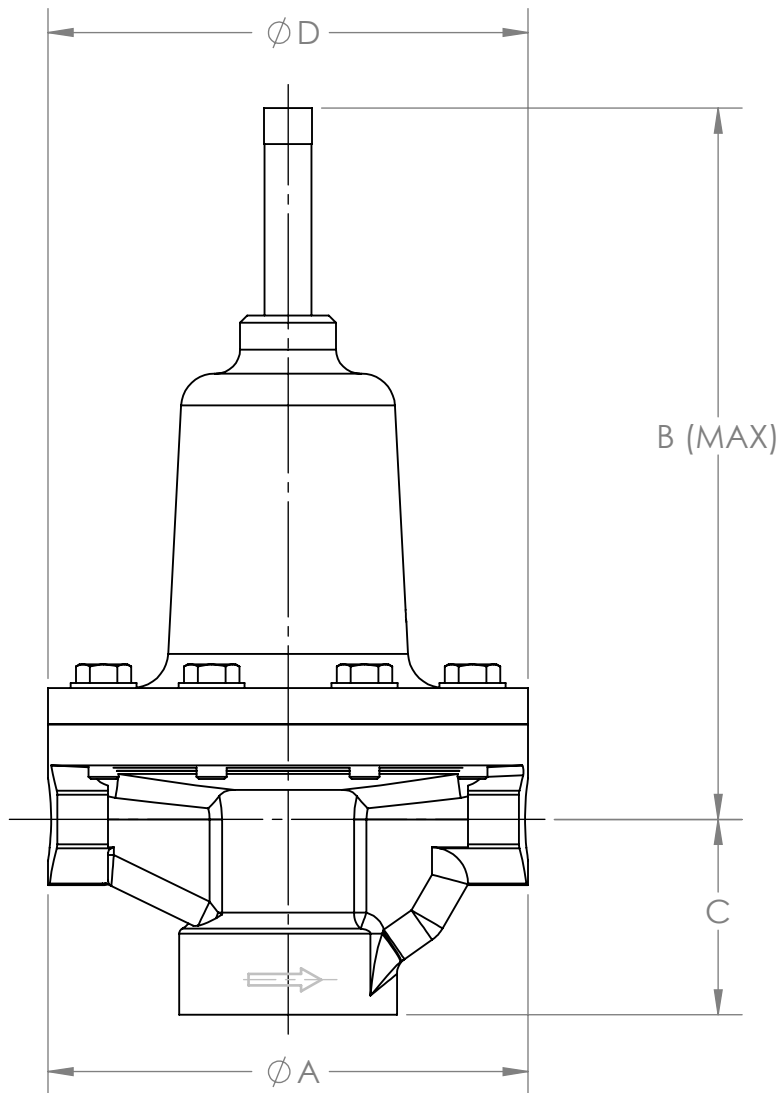

TOLERANCES

BWE, FE, TRI-C & TUBE END F-F DIM ARE $\pm 1/16"$ [1.67MM]
 ALL OTHE DIMENSIONS ARE $\pm 1/2"$ [12.7MM]



www.jordanvalve.com

1/2"-2" MARK 58G GLOBE STYLE
 PRESSUJRE REDUCING VALVE

SCALE	1:2	DATE	
DR. BY	DW	08/25/22	
CHK. BY			

MK58G

MODEL: 58G-050-NPT_Outside