

VALVE SIZE	FLANGE RATING	DIMENSIONS, INCHES				WGT. LBS.
		A	B	C	D	
2 1/2	125-150#	10.88	25.94	5.84	6.35	175
	250-300#	11.50	25.94	5.84	6.35	175
3	125-150#	11.75	25.94	5.84	6.35	190
	250-300#	12.50	25.94	5.84	6.35	190
4	125-150#	13.88	27.19	6.91	6.35	300
	250-300#	14.50	27.19	6.91	6.35	300
6	125-150#	17.75	27.94	7.72	6.35	375
	250-300#	18.62	27.94	7.72	6.35	375

① ADD 5-3/4" FOR REMOVAL OF MOTOR COVER FOR ELECTRICAL CONNECTIONS.

② FOR EXPLOSION-PROOF MOTOR, ADD 0.33" TO DIMENSION 'D'.

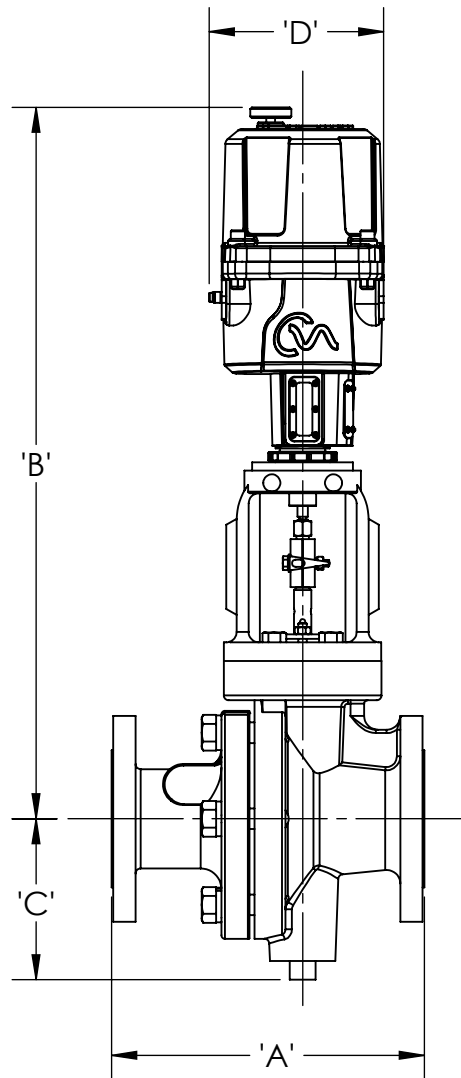

TOLERANCES

BWE, FE, TRI-C & TUBE END F-F DIM ARE $\pm 1/16"$ [1.67MM]
 ALL OTHE DIMENSIONS ARE $\pm 1/2"$ [12.7MM]

 **JORDAN VALVE** Cincinnati, Ohio
 USA
www.jordanvalve.com

2-1/2" - 6" MARK37 W/CML250

SCALE	1:8	DATE	MK37-6-CML250
DR. BY	JEM	8/9/21	
CHK. BY			
			MODEL: 37-19