

VALVE SIZE	FLANGE RATING	DIMENSIONS, INCHES				WGT. LBS.
		A	B	C	D	
2 1/2	125-150#	10.88	30.65	5.84	6.95	175
	250-300#	11.50	30.65	5.84	6.95	175
3	125-150#	11.75	30.65	5.84	6.95	190
	250-300#	12.50	30.65	5.84	6.95	190
4	125-150#	13.88	31.90	6.91	6.95	300
	250-300#	14.50	31.90	6.91	6.95	300
6	125-150#	17.75	32.66	7.72	6.95	375
	250-300#	18.62	32.66	7.72	6.95	375

① ADD 5-3/4" FOR REMOVAL OF MOTOR COVER FOR ELECTRICAL CONNECTIONS.

② FOR EXPLOSION-PROOF MOTOR, ADD 0.33" TO DIMENSION 'D'.

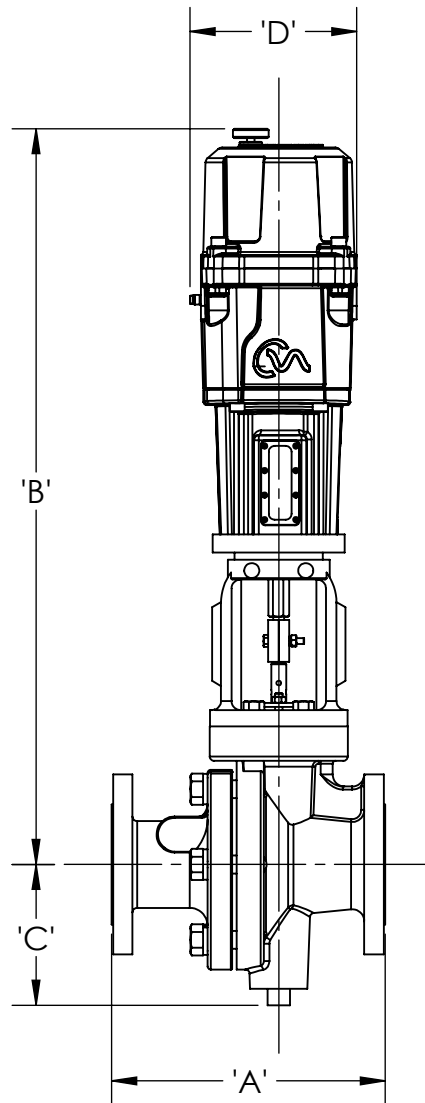

**TOLERANCES**

BWE, FE, TRI-C & TUBE END F-F DIM ARE  $\pm 1/16"$  [1.67MM]  
 ALL OTHE DIMENSIONS ARE  $\pm 1/2"$  [12.7MM]

 **JORDAN VALVE** Cincinnati, Ohio  
 USA  
[www.jordanvalve.com](http://www.jordanvalve.com)

**2-1/2" - 6" MARK37 W/CML750**

SCALE	1:8	DATE	<b>MK37-6-CML750</b>
DR. BY	JEM	8/9/21	
CHK. BY			
			MODEL: MK37-6-CML750