

SIZE DN	FLANGE PN	DIMENSIONS, MM				WGT. KGS.
		A	B	C	D	
65	10/16	287	659	148	161	79
	25/40	293	659	148	161	79
80	10/16	313	659	148	161	86
	25/40	313	659	148	161	86
100	10/16	353	691	176	161	136
	25/40	353	691	176	161	136
150	10/16	474	710	196	161	170
	25/40	474	710	196	161	170

① ADD 146MM FOR REMOVAL OF MOTOR COVER FOR ELECTRICAL CONNECTIONS.

② FOR EXPLOSION-PROOF MOTOR, ADD 8MM TO DIMENSION 'D'.

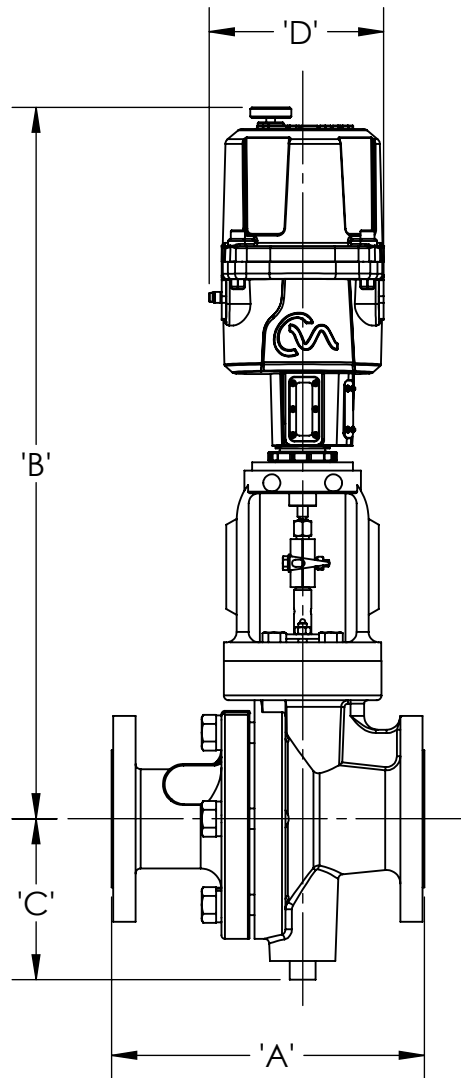

TOLERANCES

BWE, FE, TRI-C & TUBE END F-F DIM ARE $\pm 1/16"$ [1.67MM]
 ALL OTHE DIMENSIONS ARE $\pm 1/2"$ [12.7MM]



www.jordanvalve.com

65-150MM MARK37 W/CML250 (METRIC)

SCALE	1:8	DATE	MK37-6M-CML250
DR. BY	JEM	8/9/21	
CHK. BY			
			MODEL: 37-19